

Service Guide

Agilent Technologies N5181A/82A MXG Signal Generators

This guide applies to the following signal generator models:

N5181A Analog Signal Generator

N5182A Vector Signal Generator

Because of our continuing efforts to improve our products through firmware and hardware revisions, signal generator design and operation may vary from descriptions in this guide. We recommend that you use the latest revision of this guide to ensure you have up-to-date product information. Compare the print date of this guide (see bottom of page) with the latest revision, which can be downloaded from the following website:

<http://www.agilent.com/find/mxg>

Preliminary



Agilent Technologies

Manufacturing Part Number: N5180-90006

Printed in USA

September 2006

© Copyright 2006 Agilent Technologies, Inc.

Notice

The material contained in this document is provided “as is”, and is subject to being changed, without notice, in future editions.

Further, to the maximum extent permitted by applicable law, Agilent disclaims all warranties, either express or implied with regard to this manual and to any of the Agilent products to which it pertains, including but not limited to the implied warranties of merchantability and fitness for a particular purpose. Agilent shall not be liable for errors or for incidental or consequential damages in connection with the furnishing, use, or performance of this document or any of the Agilent products to which it pertains. Should Agilent have a written contract with the User and should any of the contract terms conflict with these terms, the contract terms shall control.

Questions or Comments about our Documentation?

We welcome any questions or comments you may have about our documentation. Please send us an E-mail at sources_manuals@am.exch.agilent.com.

1. Troubleshooting (Content under construction)

2. Assembly Replacement

Before You Replace an Assembly 1-1

After Replacing or Repairing an Assembly 1-1

Assemblies You Can Replace 1-1

Outer Cover 1-2

 Tools Required 1-2

 Removal Procedure. 1-2

 Replacement Procedure 1-2

Inner Top Cover 1-4

 Tools Required 1-4

 Removal Procedure 1-4

 Replacement Procedure 1-4

Inner Bottom Cover 1-6

 Tools Required 1-6

 Removal Procedure 1-6

 Replacement Procedure 1-6

Front Panel 1-8

 Tools Required 1-8

 Removal Procedure. 1-8

 Replacement Procedure 1-8

Tested USB Board 1-10

 Tools Required 1-10

 Removal Procedure. 1-10

 Replacement Procedure 1-10

AC-DC Inverter 1-12

 Tools Required 1-12

 Removal Procedure. 1-12

 Replacement Procedure 1-12

LCD 1-14

 Tools Required 1-14

 Removal Procedure. 1-14

 Replacement Procedure 1-14

EMI Display with Gasket. 1-16

 Tools Required 1-16

 Removal Procedure. 1-16

 Replacement Procedure 1-16

Key Pad. 1-18

 Tools Required 1-18

 Removal Procedure. 1-18

 Replacement Procedure 1-18

Power Switch 1-20

 Tools Required 1-20

 Removal Procedure. 1-20

 Replacement Procedure 1-20

Contents

A1 Power Supply	1-22
Tools Required	1-22
Removal Procedure	1-22
Replacement Procedure	1-22
A2 Vector Modulation Assembly	1-24
Tools Required	1-24
Removal Procedure	1-24
Replacement Procedure	1-24
A3 RF Assembly - Standard (Option UNM)	1-26
Tools Required	1-26
Removal Procedure	1-26
Replacement Procedure	1-26
A3 RF Assembly - Option 1EM	1-30
Tools Required	1-30
Removal Procedure	1-30
Replacement Procedure	1-30
A3BT1 Battery	1-34
Tools Required	1-34
Removal Procedure	1-34
Replacement Procedure	1-34
A4 Memory Chip	1-36
Tools Required	1-36
Removal Procedure	1-36
Replacement Procedure	1-36
A5 CPU	1-38
Tools Required	1-38
Removal Procedure	1-38
Replacement Procedure	1-38
Rear Panel (N5181A)	1-40
Tools Required	1-40
Removal Procedure	1-40
Replacement Procedure	1-40
Rear Panel (N5182A)	1-42
Tools Required	1-42
Removal Procedure	1-42
Replacement Procedure	1-42
B1 thru B4 Fans	1-44
Tools Required	1-44
Removal Procedure	1-44
Replacement Procedure	1-44
3. Replaceable Parts	
Ordering Information	2-1
Order Parts Fast	2-1
Shipping a Defective Assembly Back to Agilent Technologies	2-1
Frequency and Hardware Options	2-2

Assemblies and Hardware Options	2-2
Assemblies from a Top View	2-4
Assemblies from a Bottom View	2-5
Service Kits	2-6
N5181A Option UNM - N5180-xxxxx	2-6
N5182A Option UNM - N5180-xxxxx	2-6
N5181A Option 1EM - N5180-xxxxx	2-8
N5182A Option 1EM - N5180-xxxxx	2-8
Cables	2-10
Cables from a Top View	2-11
Cables from a Bottom View	2-12
Hardware	2-13
Front Panel View	2-13
Disassembled Rear Panel View	2-14
Main Chassis with Inside Covers	2-15
Outer Instrument Cover and Associated Parts	2-17
Miscellaneous	2-19
Documentation	2-19
Electrostatic Discharge (ESD) Protective Supplies	2-19
Abbreviations Used in Part Descriptions	2-20
4. Post Repair	
Running Self Test	3-1
Self Test Failure	3-2
Frequency Range and Accuracy Check	3-3
Frequency Counter Procedure	3-4
Spectrum Analyzer Procedure	3-5
Troubleshooting Problems with the Frequency Accuracy Check	3-6
Checking the Output Power	3-6
N5181A Test Procedure	3-7
N5182A Test Procedure	3-8
Troubleshooting Problems with the Output Power Check	3-9
5. Safety and Regulatory	
General Safety Considerations	4-1
Lithium Battery Disposal	4-2
Assistance	4-2
Certification	4-2

Documentation Overview

- | | |
|-----------------------------|---|
| Installation Guide | <ul style="list-style-type: none">• Safety Information• Receiving the Instrument• Environmental & Electrical Requirements• Basic Setup• Accessories• Operation Verification• Regulatory Information |
| User's Guide | <ul style="list-style-type: none">• Instrument Overview• Front Panel Operation• Security• Basic Troubleshooting |
| Programming Guide | <ul style="list-style-type: none">• Remote Operation• Status Registers• Creating & Downloading Files |
| SCPI Reference | <ul style="list-style-type: none">• SCPI Basics• Command Descriptions• Programming Command Compatibility |
| Service Guide | <ul style="list-style-type: none">• Troubleshooting• Assembly Replacement• Replaceable Parts• Post-Repair Procedures• Safety and Regulatory Information |
| Key Help^a | <ul style="list-style-type: none">• Key function description• Related SCPI commands |

^aPress the **Help** hardkey, and then the key for which you wish help.

1 Troubleshooting (Content under construction)

2 Assembly Replacement

Before You Replace an Assembly

CAUTION Many of the assemblies in this instrument are very susceptible to damage from electrostatic discharge (ESD). Perform service procedures only at a static-safe workstation and wear a grounding strap.

Be sure to review the warning and caution statements described in [Chapter 5, "Safety and Regulatory," on page 5-1](#), prior to replacing an assembly in your signal generator.

After Replacing or Repairing an Assembly

After you have replaced or repaired an assembly, certain performance tests may have to be performed. Please refer to [Chapter 4, "Post Repair," on page 4-1](#), for the list of performance tests required for each assembly.

Assemblies You Can Replace

- "Outer Cover" on page 2-2
- "Inner Top Cover" on page 2-4
- "Inner Bottom Cover" on page 2-6
- "Front Panel" on page 2-8
- "Tested USB Board" on page 2-10
- "AC-DC Inverter" on page 2-12
- "LCD" on page 2-14
- "EMI Display with Gasket" on page 2-16
- "Key Pad" on page 2-18
- "Power Switch" on page 2-20
- "A1 Power Supply" on page 2-22
- "A2 Vector Modulation Assembly" on page 2-24
- "A3 RF Assembly - Standard (Option UNM)" on page 2-26
- "A3 RF Assembly - Option 1EM" on page 2-30
- "A3BT1 Battery" on page 2-34
- "A4 Memory Chip" on page 2-36
- "A5 CPU" on page 2-38
- "Rear Panel (N5181A)" on page 2-40
- "Rear Panel (N5182A)" on page 2-42
- "B1 thru B4 Fans" on page 2-44

Outer Cover

Tools Required

- T-15 driver
- T-20 driver

Removal Procedure

Refer to [Figure 2-1](#) for this procedure.

1. Disconnect the power cord.
2. Using the T-20 driver, loosen the two screws (1) and remove the strap handle (2).
3. Using the T-20 driver, remove the two hole plugs (not shown in photo) from the opposite side of the instrument.
4. Using the T-15 driver, remove the center screws from the four rear-panel feet (3).
5. Remove the four bottom feet (4) from the cover by lifting the tab and sliding the foot toward the tab.
6. Place the signal generator flat with the A3 RF Assembly facing up.
7. Lift the back of the signal generator, so it tilts forward on to the front panel, and slide the outer cover (5) back to remove it from the frame.

Replacement Procedure

1. Reverse the order of the removal procedures.
2. Torque all screws to 21 in-lbs.

Figure 2-1 Outer Cover Removal



Inner Top Cover

Tools Required

- T-10 driver

Removal Procedure

Refer to [Figure 2-2](#) for this procedure.

1. Disconnect the power cord.
2. Remove the outer-cover from the signal generator, refer to ["Outer Cover" on page 2-2](#).
3. Place the signal generator flat and upright with the front panel facing you.
4. Using the T-10 driver, remove the nine flat-top screws (1) from the inner top cover (2).
5. Using the T-10 driver, remove the screw (3) from the rear panel.
6. Remove the inner top cover.

Replacement Procedure

1. Reverse the order of the removal procedures.
2. Torque all screws to 9 in-lbs.

Figure 2-2 Inner Top Cover Removal

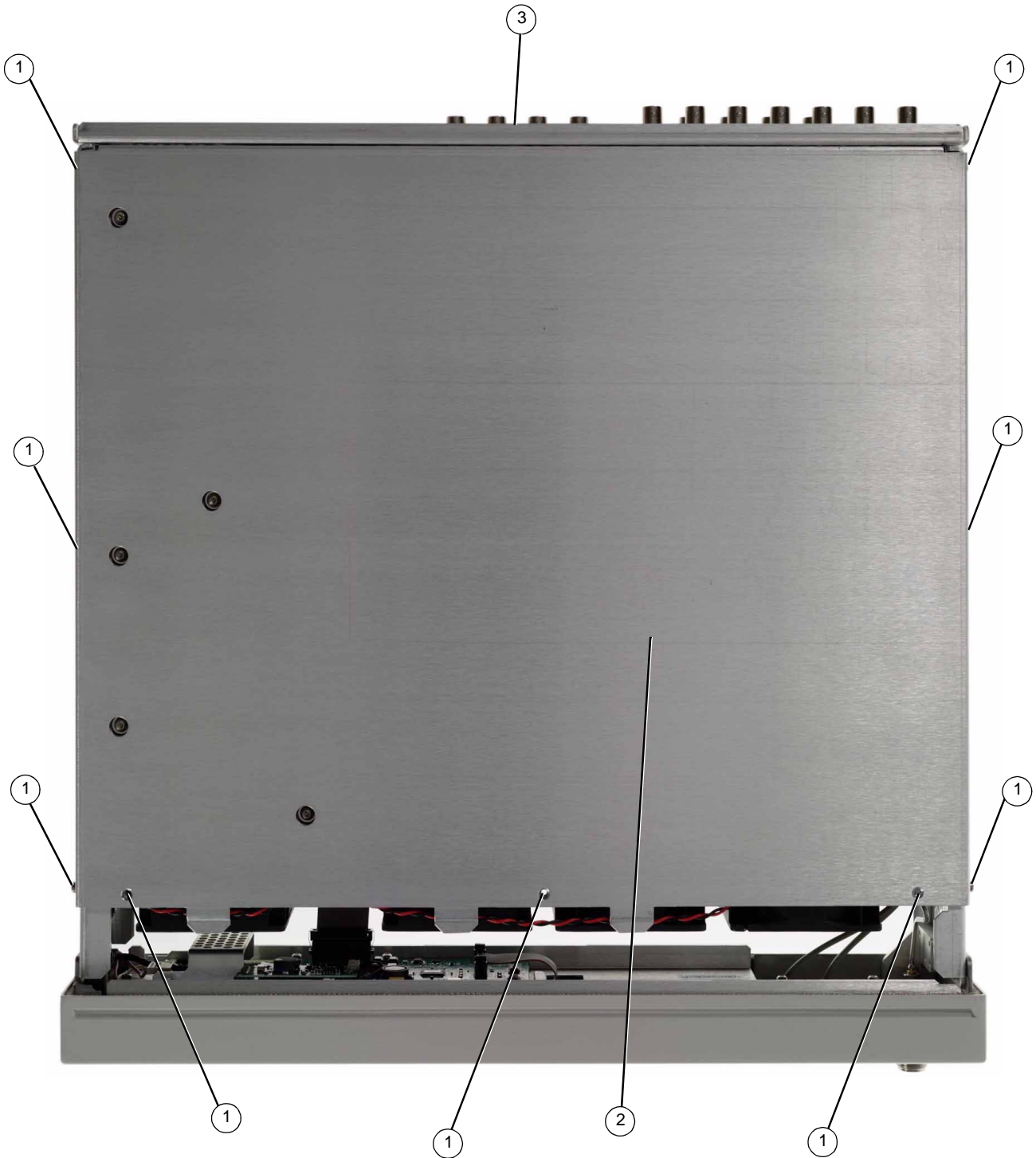

Inner Bottom Cover

Tools Required

- T-10 driver

Removal Procedure

Refer to [Figure 2-3](#) for this procedure.

1. Disconnect the power cord.
2. Remove the outer-cover from the signal generator, refer to ["Outer Cover" on page 2-2](#).
3. Place the signal generator flat and upside down with the front panel facing you.
4. Using the T-10 driver, remove the eleven flat-top screws (1) from the inner bottom cover (2).
5. Using the T-10 driver, remove the screw (3) from the rear panel.
6. Remove the inner bottom cover.

Replacement Procedure

1. Reverse the order of the removal procedures.
2. Torque all screws to 9 in-lbs.

Figure 2-3 Inner Bottom Cover

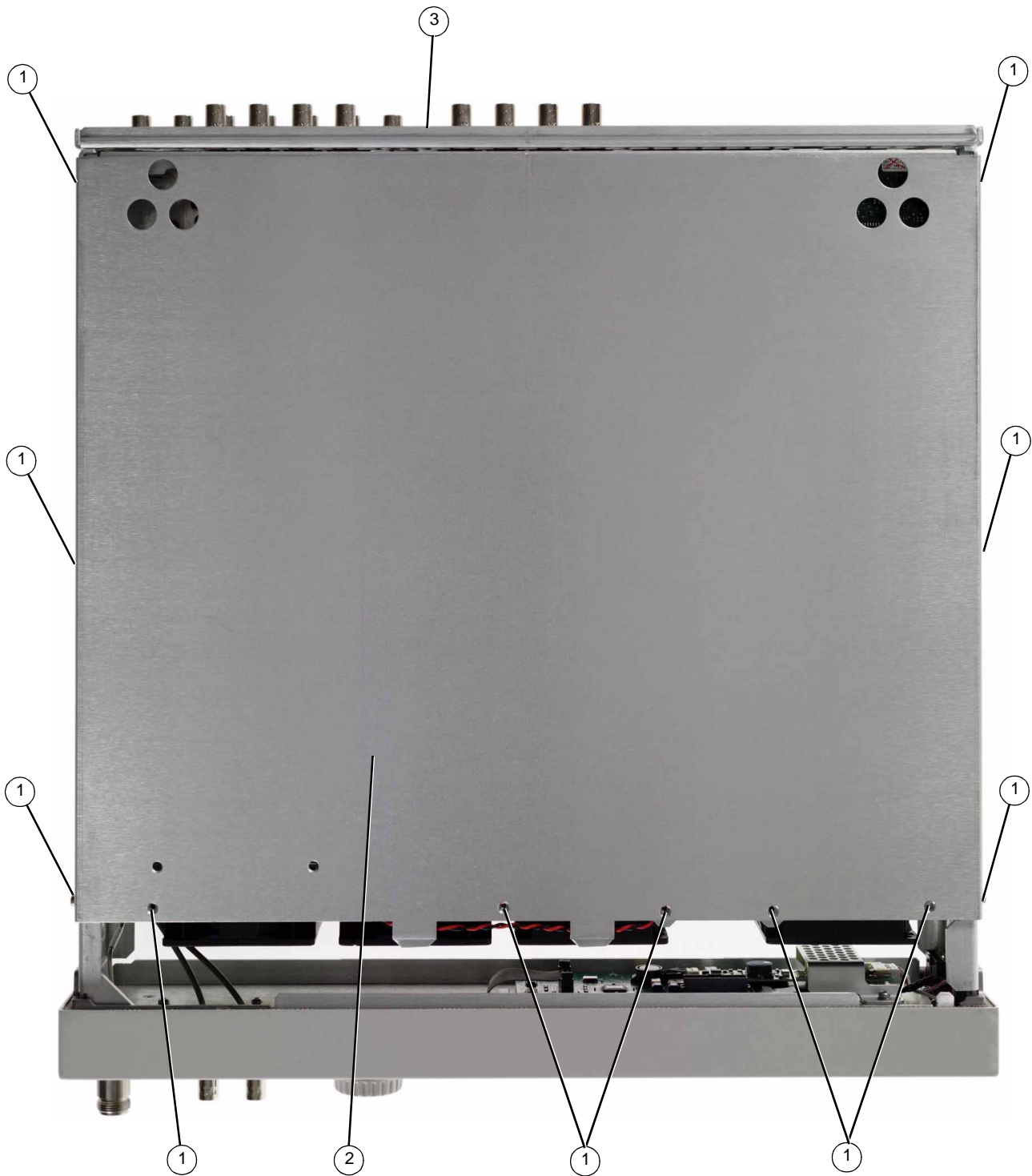

Front Panel

Tools Required

- T-20 driver
- needle-nose pliers

Removal Procedure

Refer to [Figure 2-4](#) for this procedure.

1. Disconnect the power cord.
2. Remove the covers from the signal generator, refer to "[Outer Cover](#)" on page 2-2, "[Inner Top Cover](#)" on page 2-4, and "[Inner Bottom Cover](#)" on page 2-6.
3. With the signal generator on its side disconnect W1 and W2 from the A3 RF Assembly, by squeezing the cable connector and pulling the cable away from the signal generator.
4. Release W2 from the cable clips.
5. For N5182A instruments, place the signal generator flat with the A2 Vector Modulation Assembly facing you, use the needle-nose pliers to disconnect the following cables,
 - W3 (I Input) from A2J15
 - W4 (Q Input) from A2J16
6. Remove the chassis grommet before pulling W3 and W4 thru the chassis (N5182A only).
7. With the signal generator flat and the A3 Motherboard facing you, use the T-20 driver to remove the four screws (1) from the sides of the chassis

CAUTION Before removing the front panel from the signal generator, lift and support the front of the signal generator's frame.

8. Slide the front panel over the RF output connector.
9. Remove the front panel.

Replacement Procedure

1. Reverse the order of the removal procedure.
2. Torque all screws to 21 in-lbs.
3. Perform the post-repair performance tests that pertain to this replacement procedure, see [Chapter 4, Post Repair](#).

Figure 2-4 Front Panel

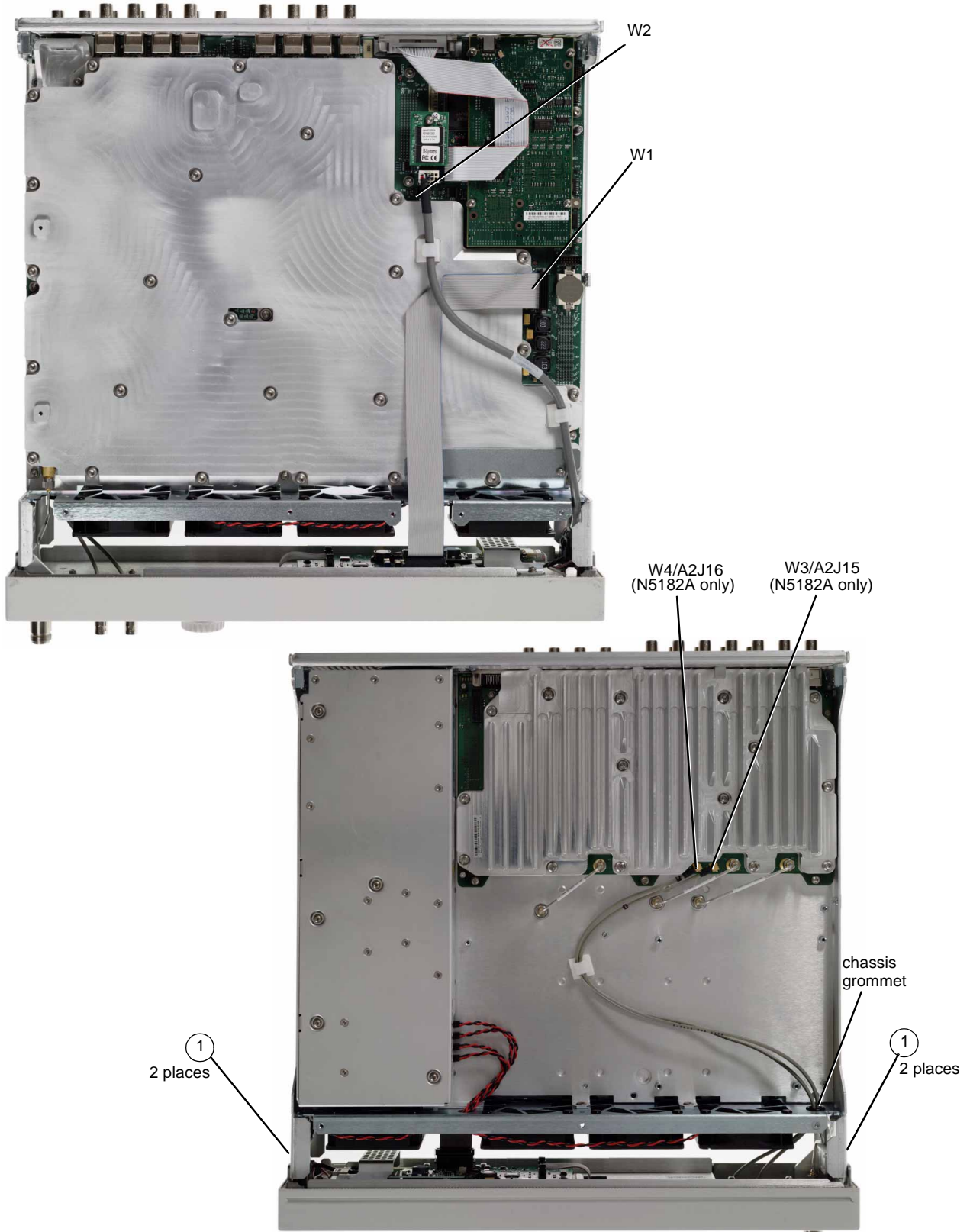

Tested USB Board

Tools Required

- T-10 driver

Removal Procedure

Refer to [Figure 2-4](#) for this procedure.

1. Disconnect the power cord.
2. Remove the covers from the signal generator, refer to "[Outer Cover](#)" on page 2-2, "[Inner Top Cover](#)" on page 2-4, and "[Inner Bottom Cover](#)" on page 2-6.
3. Remove the front panel from the signal generator, refer to "[Front Panel](#)" on page 2-8.
4. Using the T-10 driver, remove the screw (1) securing the USB board to the front panel.
5. Remove USB board

Replacement Procedure

1. Reverse the order of the removal procedure.
2. Torque screw to 9 in-lbs.
3. Perform the post-repair performance tests that pertain to this replacement procedure, see [Chapter 4, Post Repair](#).

Figure 2-5 Tested USB Board

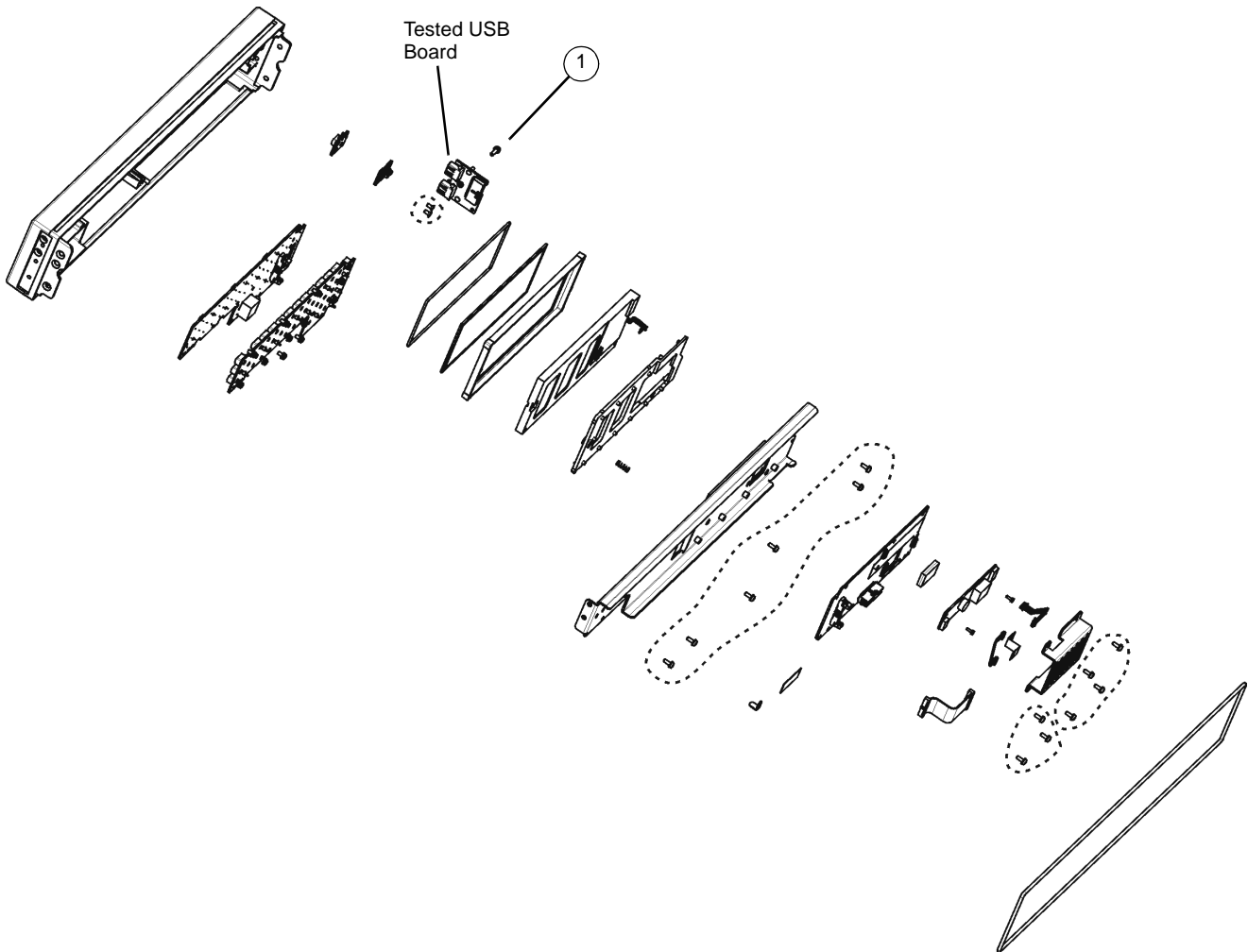

AC-DC Inverter

Tools Required

- T-10 driver

Removal Procedure

Refer to [Figure 2-6](#) for this procedure.

1. Disconnect the power cord.
2. Remove the covers from the signal generator, refer to ["Outer Cover" on page 2-2](#), ["Inner Top Cover" on page 2-4](#), and ["Inner Bottom Cover" on page 2-6](#).
3. Remove the front panel from the signal generator, refer to ["Front Panel" on page 2-8](#).
4. Disconnect the W2 ribbon cable (not shown in [Figure 2-6](#)) from the AC-DC Inverter Interface board (1).
5. Using the T-10 driver, remove the four screws (2) that secure the Inverter shield (3) to the AC-DC Inverter Interface board (1).
6. Disconnect the Power Switch cable (4) from the AC-DC Inverter Interface board (1).
7. Disconnect the LCD 2 wire cable (5) from the Inverter board (6).
8. Disconnect the ribbon cable (7) from the Keypad Board (8).
9. Disconnect the LCD flat flex cable (9) from the Interface board (1).
10. Using the T-10 driver, remove the three screws (10) that secure the Interface board (1) to the front panel sub panel (11).
11. Remove the AC-DC Inverter.

Replacement Procedure

1. Reverse the order of the removal procedure.
2. Torque all screws to 9in-lbs.
3. Perform the post-repair performance tests that pertain to this replacement procedure, see [Chapter 4, Post Repair](#).

Figure 2-6 AC-DC Inverter

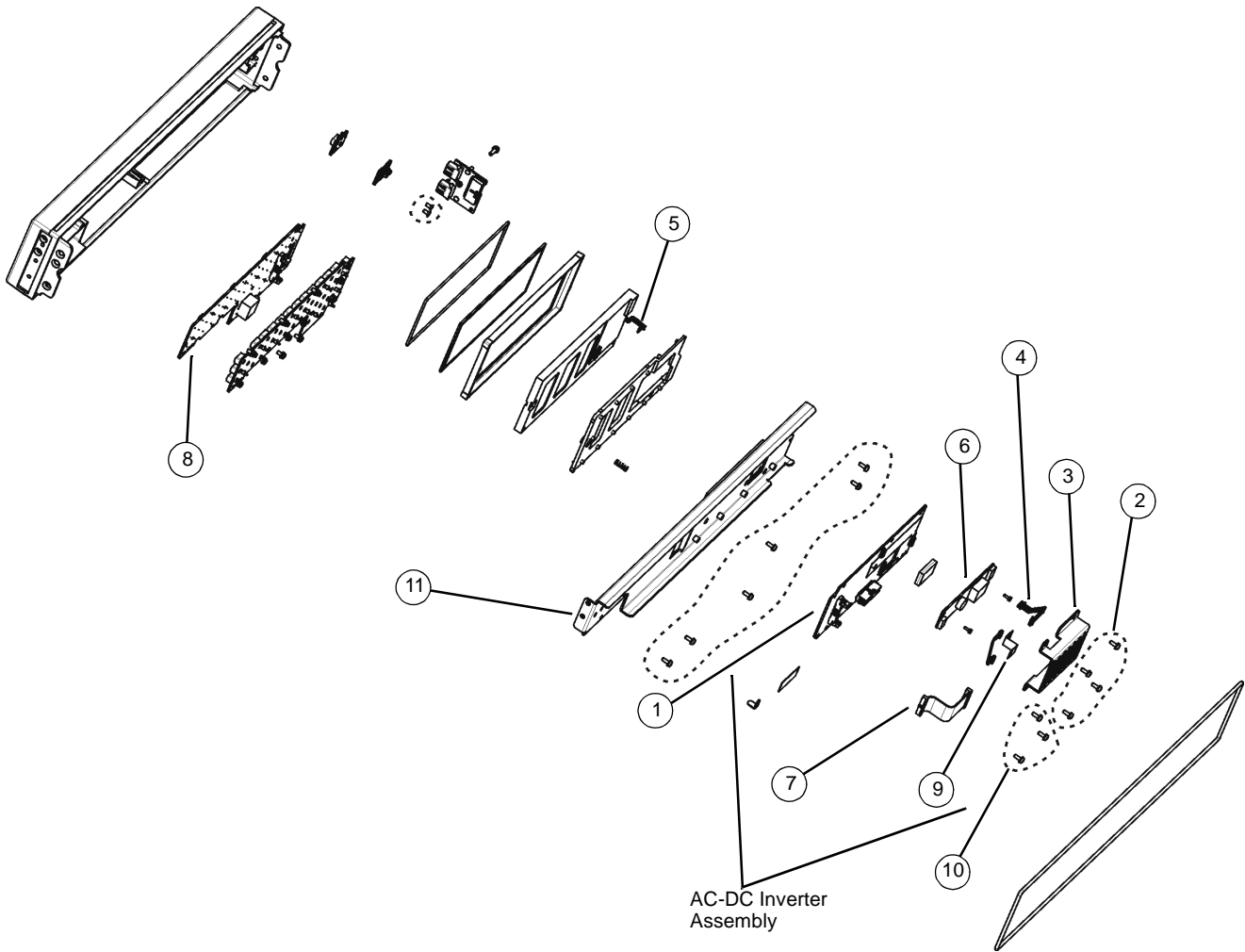

LCD

Tools Required

- T-10 driver

Removal Procedure

Refer to [Figure 2-4](#) for this procedure.

1. Disconnect the power cord.
2. Remove the covers from the signal generator, refer to "[Outer Cover](#)" on page 2-2, "[Inner Top Cover](#)" on page 2-4, and "[Inner Bottom Cover](#)" on page 2-6.
3. Remove the front panel from the signal generator, refer to "[Front Panel](#)" on page 2-8.
4. Remove the AC-DC Inverter kit from the signal generator, refer to "[AC-DC Inverter](#)" on page 2-12.
5. Using the T-10 driver, remove the six screws (1) that secure the sub panel (2) to the front panel.
6. Remove the sub panel.
7. Remove the LCD.

Replacement Procedure

1. Reverse the order of the removal procedure.
2. Torque all screws to 9 in-lbs.
3. Perform the post-repair performance tests that pertain to this replacement procedure, see [Chapter 4, Post Repair](#).

Figure 2-7 LCD Kit

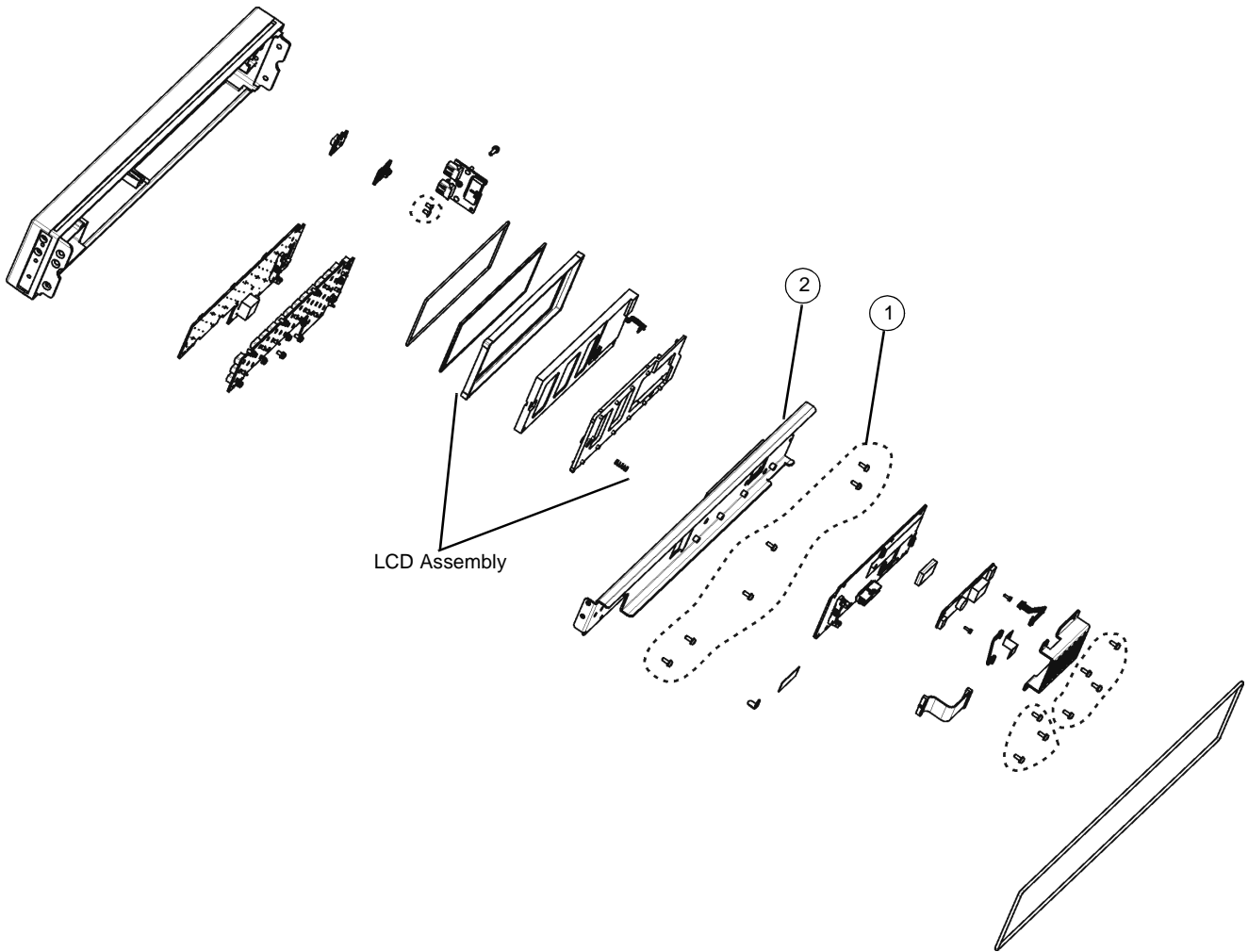

EMI Display with Gasket

Tools Required

- T-10 driver

Removal Procedure

Refer to [Figure 2-4](#) for this procedure.

1. Disconnect the power cord.
2. Remove the covers from the signal generator, refer to ["Outer Cover"](#) on page 2-2, ["Inner Top Cover"](#) on page 2-4, and ["Inner Bottom Cover"](#) on page 2-6.
3. Remove the front panel from the signal generator, refer to ["Front Panel"](#) on page 2-8.
4. Remove the AC-DC Inverter kit from the signal generator, refer to ["AC-DC Inverter"](#) on page 2-12.
5. Remove the LCD kit from the signal generator, refer to ["LCD"](#) on page 2-14.
6. Remove the EMI display (1).

Replacement Procedure

1. Reverse the order of the removal procedure.

NOTE Be sure to place the new EMI display into the pocket of the front panel frame with the "black dot", located on one corner of the EMI display, facing upwards.

2. Torque all screws to 9 in-lbs.
3. Perform the post-repair performance tests that pertain to this replacement procedure, see [Chapter 4, Post Repair](#).

Figure 2-8 EMI Display with Gasket

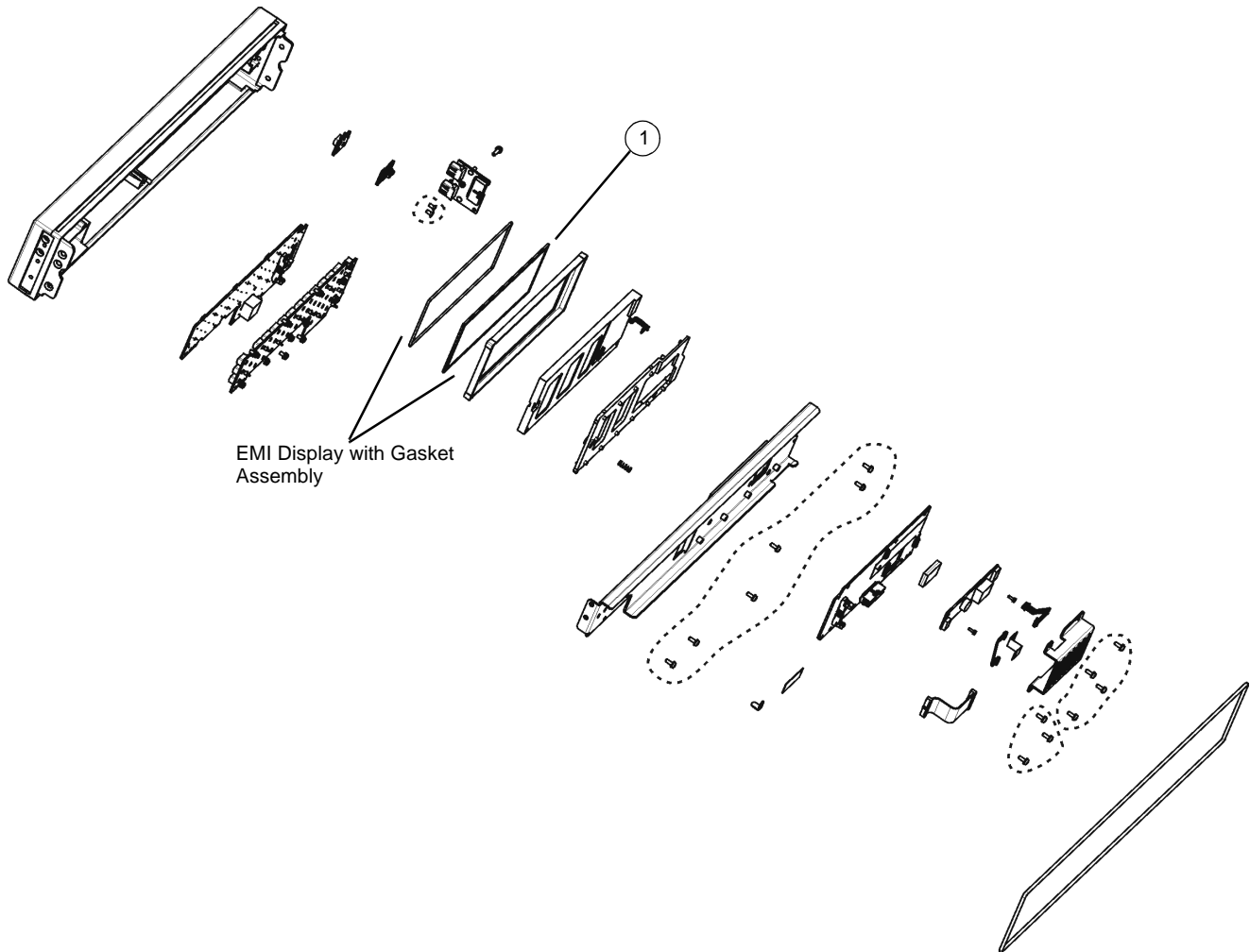

Key Pad

Tools Required

- T-10 driver

Removal Procedure

Refer to [Figure 2-4](#) for this procedure.

1. Disconnect the power cord.
2. Remove the covers from the signal generator, refer to "[Outer Cover](#)" on page 2-2, "[Inner Top Cover](#)" on page 2-4, and "[Inner Bottom Cover](#)" on page 2-6.
3. Remove the front panel from the signal generator, refer to "[Front Panel](#)" on page 2-8.
4. Remove the AC-DC Inverter kit from the signal generator, refer to "[AC-DC Inverter](#)" on page 2-12.
5. Remove the LCD kit from the signal generator, refer to "[LCD](#)" on page 2-14.
6. Remove the EMI Display and gasket from the signal generator, refer to "[EMI Display with Gasket](#)" on page 2-16.
7. Using the T-10 driver, remove the twelve screws (1) that secure the Key Pad (2) to the front panel frame.
8. Remove the Key Pad.

Replacement Procedure

1. Reverse the order of the removal procedure.

NOTE Hand start the two screws labeled "A" and "B" until they are snug, then install the remaining ten screws.

2. Torque all screws to 9 in-lbs.
3. Perform the post-repair performance tests that pertain to this replacement procedure, see [Chapter 4, Post Repair](#).

Figure 2-9 Key Pad

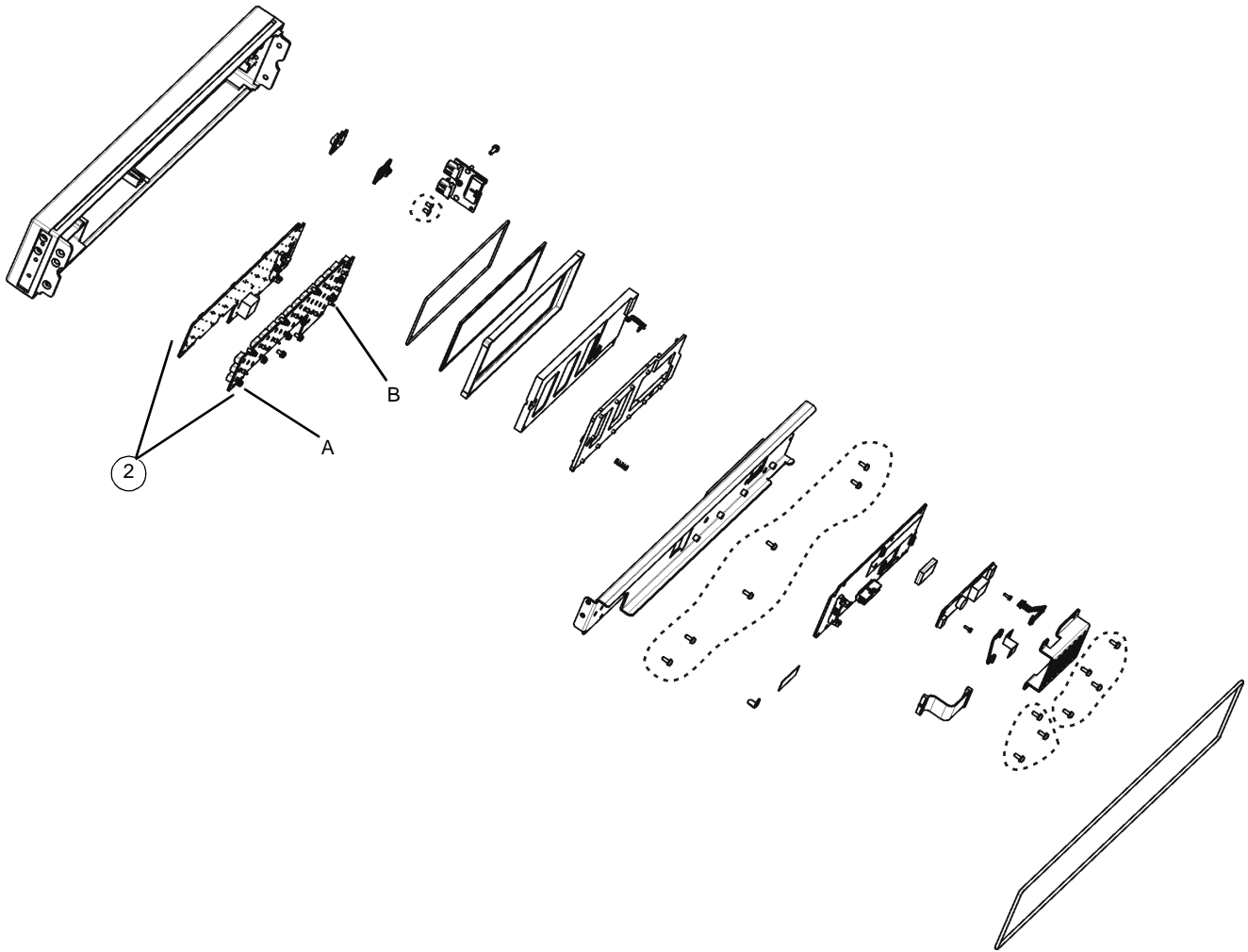

Power Switch

Tools Required

- T-10 driver

Removal Procedure

Refer to [Figure 2-4](#) for this procedure.

1. Disconnect the power cord.
2. Remove the covers from the signal generator, refer to "[Outer Cover](#)" on page 2-2, "[Inner Top Cover](#)" on page 2-4, and "[Inner Bottom Cover](#)" on page 2-6.
3. Remove the front panel from the signal generator, refer to "[Front Panel](#)" on page 2-8.
4. Remove the AC-DC Inverter kit from the signal generator, refer to "[AC-DC Inverter](#)" on page 2-12.
5. Remove the LCD kit from the signal generator, refer to "[LCD](#)" on page 2-14.
6. Remove the EMI Display and gasket from the signal generator, refer to "[EMI Display with Gasket](#)" on page 2-16.
7. Using the T-10 driver, remove the two screws (1) that secure the Power Switch kit (2) to the front panel frame.
8. Remove the Power Switch.

Replacement Procedure

1. Reverse the order of the removal procedure.
2. Torque all screws to 9in-lbs.
3. Perform the post-repair performance tests that pertain to this replacement procedure, see [Chapter 4, Post Repair](#).

Figure 2-10 Power Switch

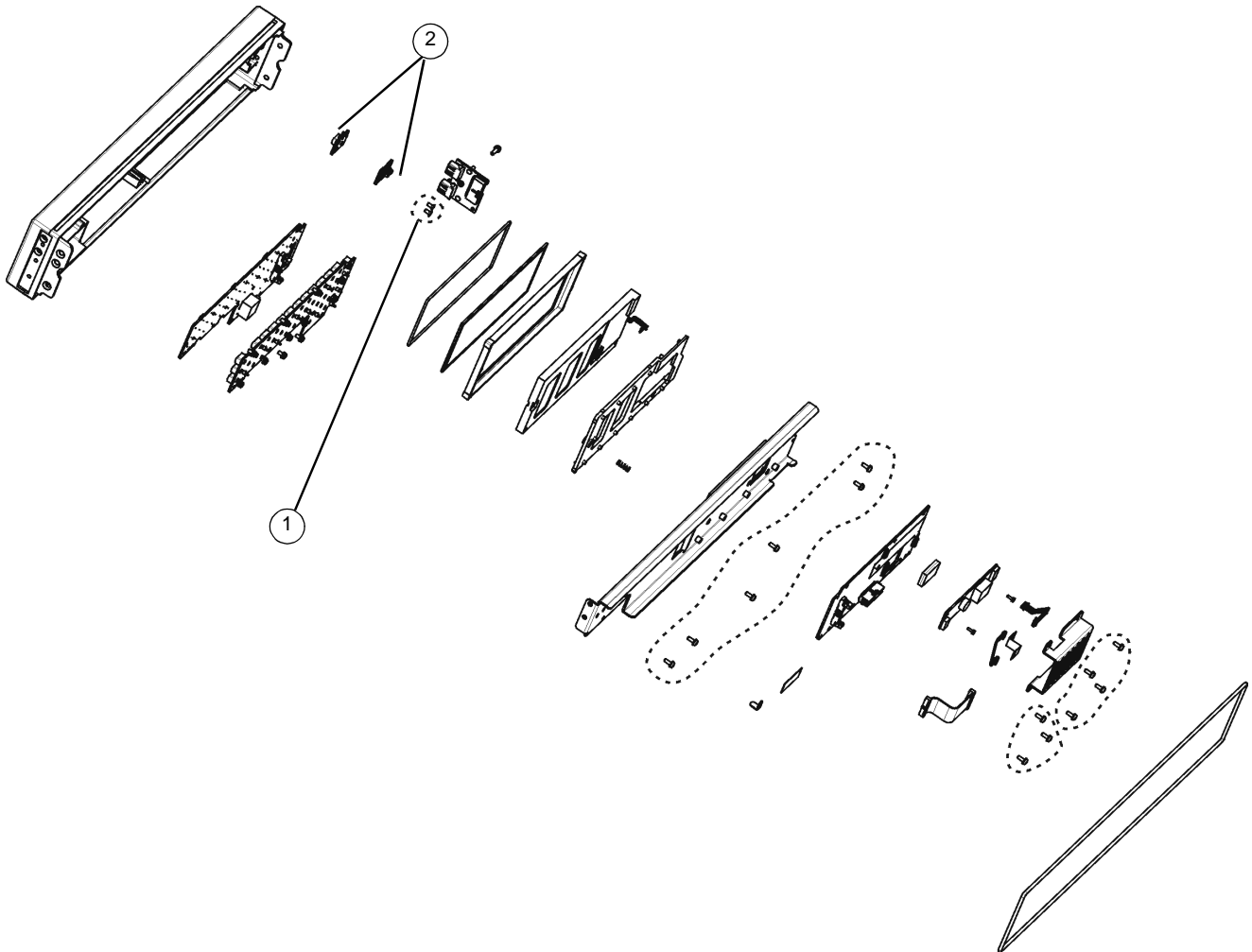

A1 Power Supply

Tools Required

- T-10 driver

Removal Procedure

Refer to [Figure 2-11](#) for this procedure.

1. Disconnect the power cord.
2. Remove the covers from the signal generator, refer to "[Outer Cover](#)" on [page 2-2](#), and "[Inner Top Cover](#)" on [page 2-4](#).
3. Remove the rear panel from the signal generator, refer to "[Rear Panel \(N5181A\)](#)" on [page 2-40](#).

NOTE The rear panel must be removed so the power connector on the A1 Power Supply can be disconnected from the A3 RF Assembly without damaging the connector pins.

4. Place the signal generator flat and upright with the front panel facing you.
5. Using the T-10 driver, press the connector latch to disconnect B1W1 thru B4W1 from the A1 Power Supply.
6. Using the T-10 driver, remove the five screws (1) that secure the A1 Power Supply to the chassis.
7. Remove the A1 Power Supply.

Replacement Procedure

1. Reverse the order of the removal procedure.
2. Torque all screws to 9 in-lbs.
3. Perform the post-repair performance tests that pertain to this replacement procedure, see [Chapter 4, Post Repair](#).

Figure 2-11 A1 Power Supply

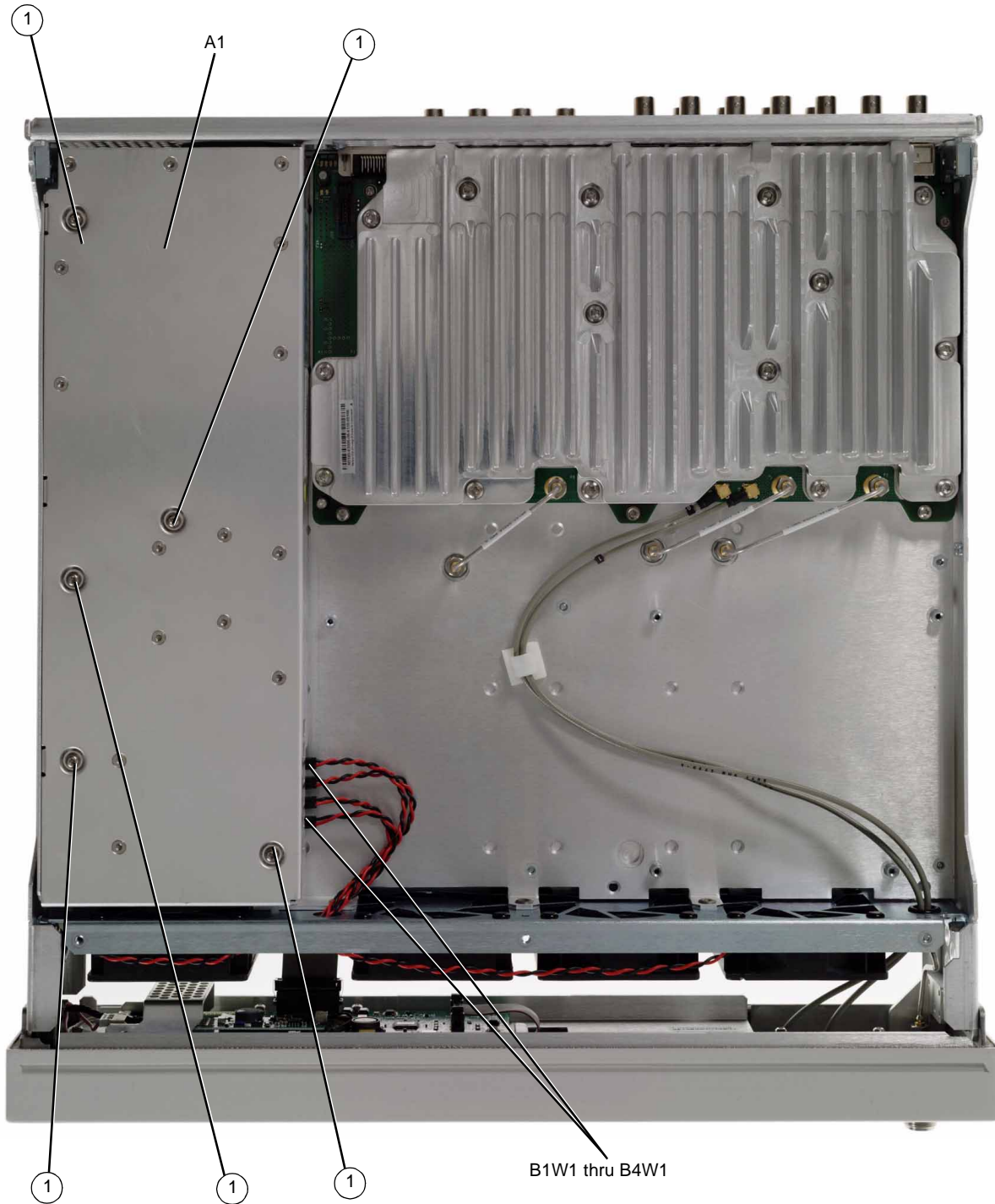

A2 Vector Modulation Assembly

Tools Required

- T-10 driver
- 5/16" open-ended wrench

Removal Procedure

Refer to [Figure 2-12](#) for this procedure.

1. Disconnect the power cord.
2. Remove the covers from the signal generator. Refer to "Outer Cover" on page 2-2, "Inner Top Cover" on page 2-4, and "Inner Bottom Cover" on page 2-6.
3. Remove the rear panel from the signal generator, refer to "Rear Panel (N5181A)" on page 2-40.

NOTE The rear panel must be removed so the 144 pin connector on the A2 Vector Modulation Assembly can be disconnected from the A3 RF Assembly without damaging the connector pins.

4. Place the signal generator flat with the A2 Vector Modulation Assembly facing up and the rear panel facing you.
5. Using the 5/16" open-ended wrench, disconnect W5, W6, and W7.
6. Using the needle-nose pliers to disconnect the following cables,
 - W3 (I Input) from A3J15
 - W4 (Q Input) from A3J16.
7. Using the T-10 driver, remove the five screws (1) that connect the A2 Vector Modulation Assembly to the chassis.
8. Place your thumbs under the BNC connectors and push up on the A2 Vector Modulation Assembly to release it from the 144 pin connector.
9. Remove the A2 Vector Modulation Assembly.

Replacement Procedure

1. Reverse the order of the removal procedure.
2. Torque all T-10 screws to 9 in-lbs.
3. Torque all BNC connectors to 8 in-lbs.
4. Perform the post-repair performance tests that pertain to this replacement procedure, see [Chapter 4, Post Repair](#).

Figure 2-12 A2 Vector Modulation Assembly

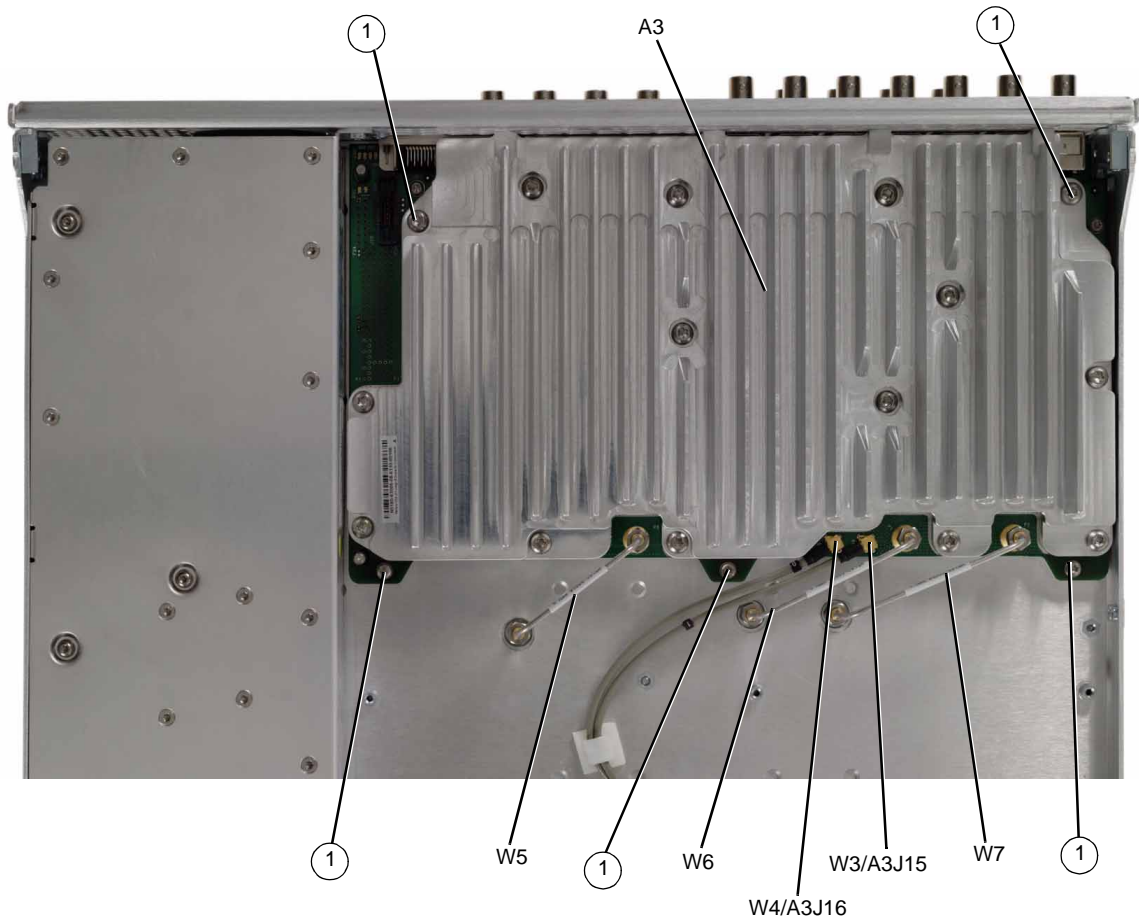

A3 RF Assembly - Standard (Option UNM)

WARNING Do not disconnect the RF connector cable from the A3 RF Assembly or the RF connector itself. Removing the cable will result in instrument failure.

Tools Required

- T-10 driver
- 5/16" open-ended wrench
- common screwdriver

Removal Procedure

Refer to [Figure 2-13](#), [Figure 2-14](#) and [Figure 2-15](#) for this procedure.

NOTE The RF Connector bracket will need to be disconnected from the chassis before the A3 RF Assembly can be removed.

NOTE Pry slots have been provided on both sides of the A3 RF Assembly to aid in removing the board.

1. Disconnect the power cord.
2. Remove the covers from the signal generator. Refer to ["Outer Cover" on page 2-2](#), ["Inner Top Cover" on page 2-4](#), and ["Inner Bottom Cover" on page 2-6](#).
3. Place the signal generator flat with the A2 Vector Modulation Assembly facing up and the rear panel facing you (N5182A only).
4. Using the 5/16" open-ended wrench, remove W5, W6, and W7 (N5182A only).
5. Position the signal generator flat with the A3 RF Assembly facing up.
6. Remove the following assemblies, in the order listed
 - a. ["A4 Memory Chip" \(see page 2-36\)](#)
 - b. ["A5 CPU" \(see page 2-38\)](#)
 - c. ["Rear Panel \(N5181A\)" \(see page 2-40\)](#) or ["Rear Panel \(N5182A\)" \(see page 2-42\)](#)
 - d. ["Front Panel" \(see page 2-8\)](#)
7. Using the T-10 driver, remove the 10 screws (1) that connect the A3 RF Assembly to the chassis.
8. Using the T-10 driver, remove the 3 screws (2) that connect the RF Connector bracket to the chassis.

CAUTION The RF Connector can be easily damaged. Use extreme caution when disconnecting the RF Connector bracket from the instrument chassis.

9. Place the tip of the medium common screwdriver into one of the three pry slots on the A3 RF Assembly and twist screwdriver to release the board from the connector pins, see [Figure 2-15](#).
10. Repeat [Step 9](#) with the other two pry slots.
11. Remove the A3 RF Assembly.

Replacement Procedure

1. Reverse the order of the removal procedure.
2. Torque all screws to 21 in-lbs.
3. Torque all BNC connectors to 8 in-lbs.
4. Perform the post-repair performance tests that pertain to this replacement procedure, see [Chapter 4, Post Repair](#).

Figure 2-13 A3 RF Assembly - Standard (1 of 3)

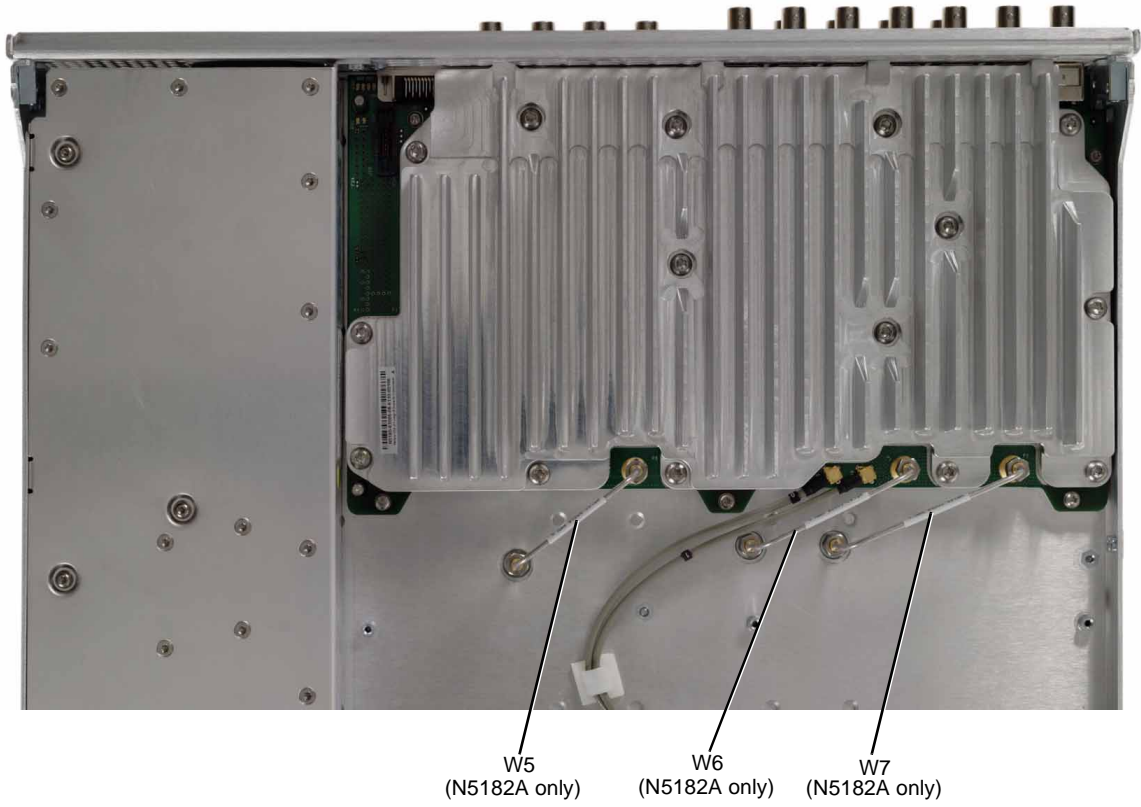

Figure 2-14 A3 RF Assembly - Standard (2 of 3)

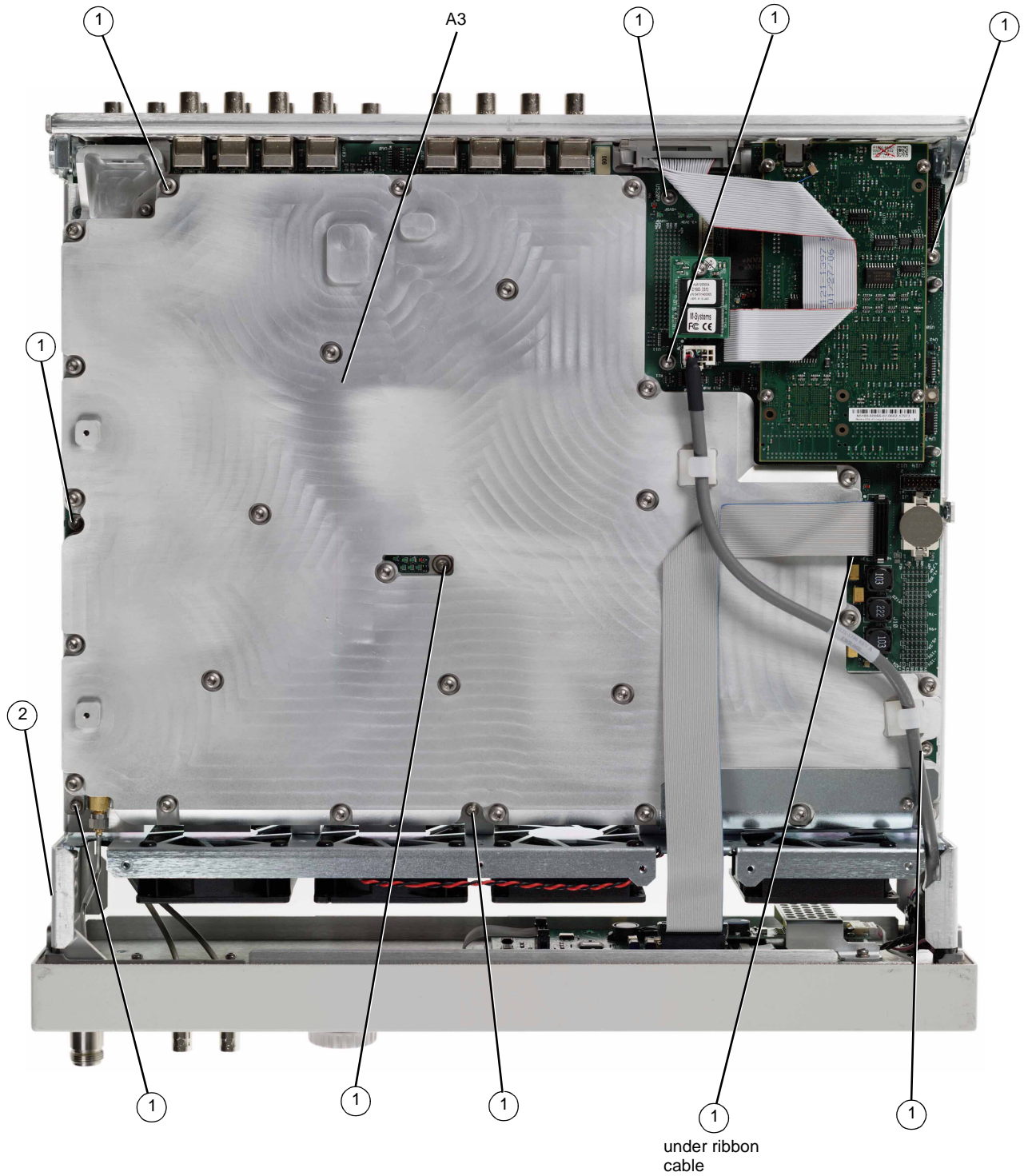
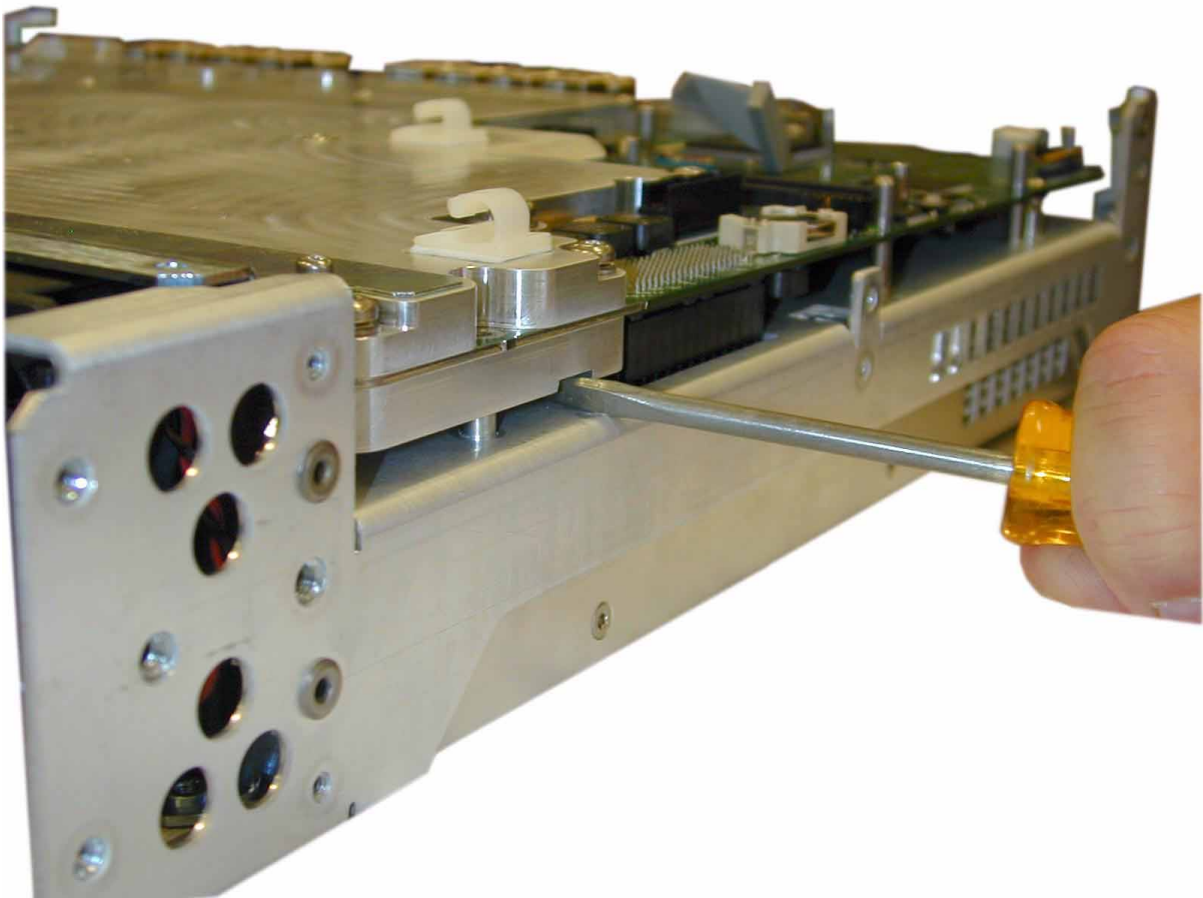

Figure 2-15 A3 RF Assembly - Standard (3 of 3)



A3 RF Assembly - Option 1EM

WARNING Do not disconnect the RF connector cable from the A3 RF Assembly or the RF connector itself. Removing the cable will result in instrument failure.

Tools Required

- T-10 driver
- 5/16" open-ended wrench
- common screwdriver

Removal Procedure

Refer to [Figure 2-16](#), [Figure 2-17](#) and [Figure 2-18](#) for this procedure.

NOTE Pry slots have been provided on both sides of the A3 RF Assembly to aid in removing the board.

1. Disconnect the power cord.
2. Remove the covers from the signal generator. Refer to ["Outer Cover" on page 2-2](#), ["Inner Top Cover" on page 2-4](#), and ["Inner Bottom Cover" on page 2-6](#).
3. Place the signal generator flat with the A2 Vector Modulation Assembly facing up and the rear panel facing you (N5182A only).
4. Using the 5/16" open-ended wrench, disconnect W5, W6, and W7 (N5182A only).
5. Position the signal generator flat with the A3 RF Assembly facing up.
6. Remove the following assemblies, in the order listed
 - a. ["A4 Memory Chip" \(see page 2-36\)](#)
 - b. ["A5 CPU" \(see page 2-38\)](#)
 - c. ["Rear Panel \(N5181A\)" \(see page 2-40\)](#) or ["Rear Panel \(N5182A\)" \(see page 2-42\)](#)
 - d. ["Front Panel" \(see page 2-8\)](#)
7. Using the T-10 driver, remove the 10 screws (1) that connect the A3 RF Assembly to the chassis.
8. Place the tip of the medium common screwdriver into one of the three pry slots on the A3 RF Assembly and twist screwdriver to release the board from the connector pins, see [Figure 2-18](#).
9. Repeat [Step 8](#) with the other two pry slots.
10. Remove the A3 RF Assembly.

Replacement Procedure

1. Reverse the order of the removal procedure.
2. Torque all screws to 21 in-lbs.
3. Torque all BNC connectors to 8 in-lbs.
4. Perform the post-repair performance tests that pertain to this replacement procedure, see [Chapter 4, Post Repair](#).

Figure 2-16 A3 RF Assembly - 1EM (1 of 3)

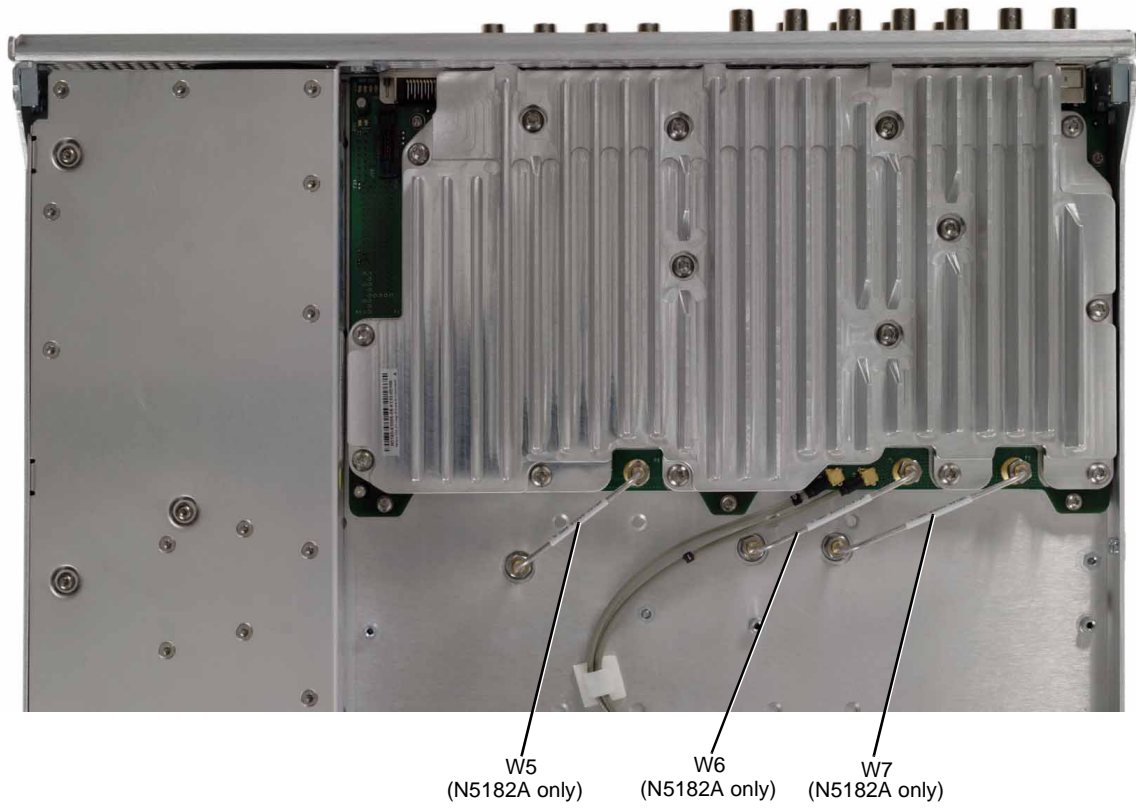

Figure 2-17 A3 RF Assembly - 1EM (2 of 3)

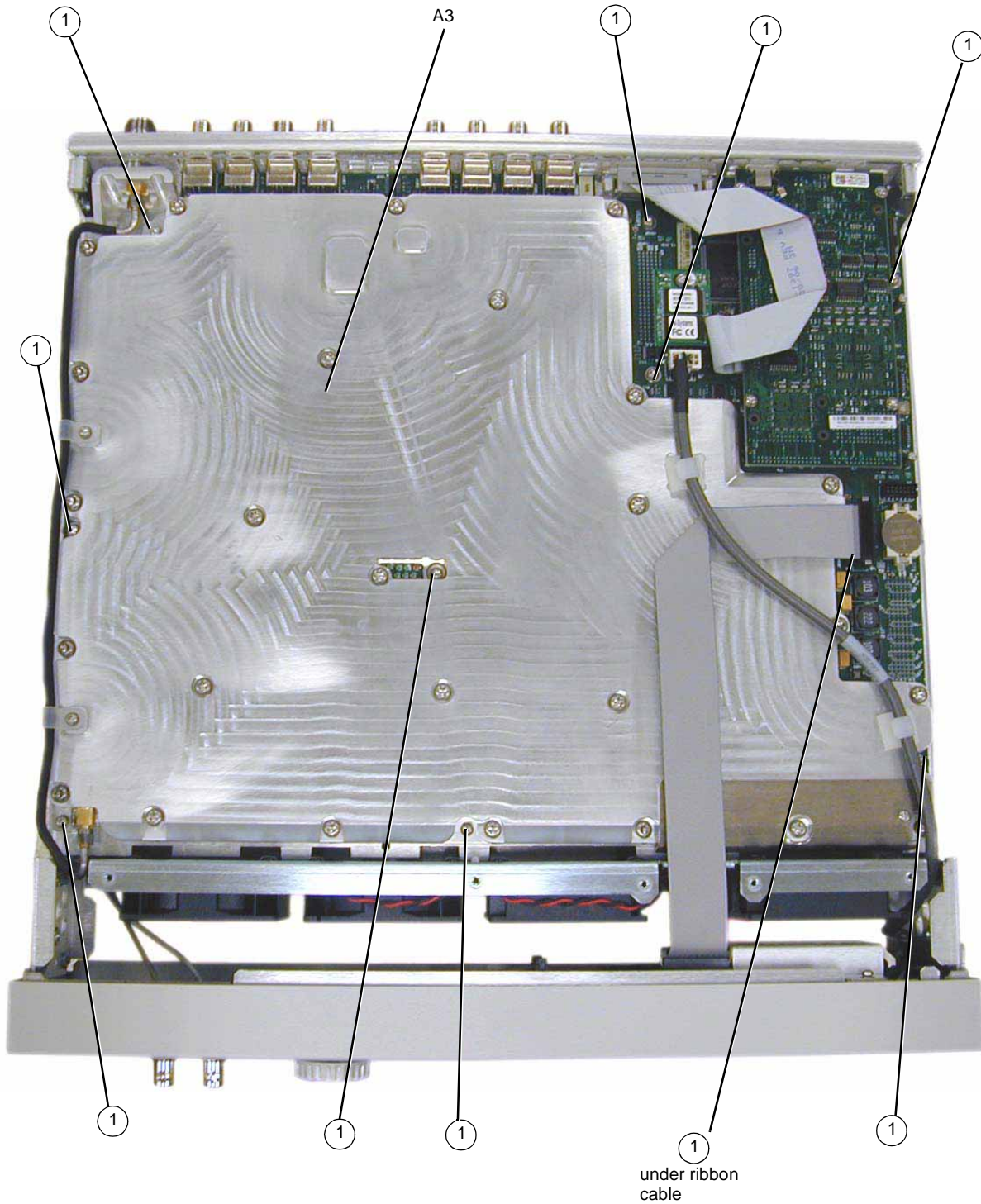
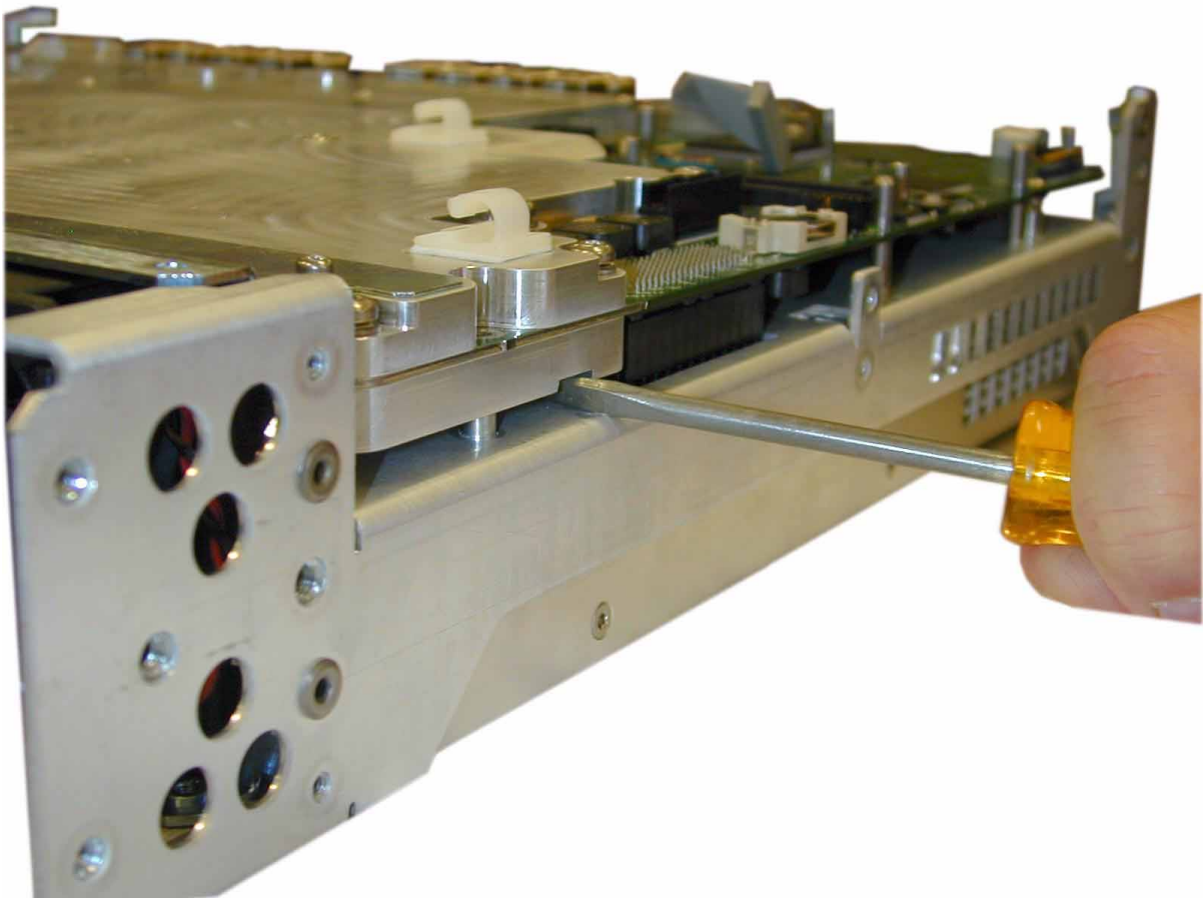

Figure 2-18 A3 RF Assembly - 1EM (3 of 3)



A3BT1 Battery

WARNING This battery contains lithium. Do not incinerate or puncture this battery. Do not install this battery backwards. To dispose of the battery in a safe manner, refer to ["Lithium Battery Disposal"](#) on [page 5-2](#).

Tools Required

- T-10 driver
- small common screw driver

Removal Procedure

Refer to [Figure 2-19](#) for this procedure.

1. Disconnect the power cord.
2. Remove the covers from the signal generator. Refer to ["Outer Cover"](#) on [page 2-2](#) and ["Inner Bottom Cover"](#) on [page 2-6](#).
3. Position the signal generator flat with the A3 RF Assembly facing up and the front panel towards you.
4. Using the flat-head screw driver, remove the A3BT1 by leveraging the battery out of its socket.

Replacement Procedure

1. Reverse the remaining steps of the removal procedure.

NOTE To install the battery, the positive side is aligned with the positive sign on the A3 RF Assembly's battery clip.

2. Perform the post-repair performance tests that pertain to this replacement procedure, see [Chapter 4, Post Repair](#).

Figure 2-19 A3BT1 Battery

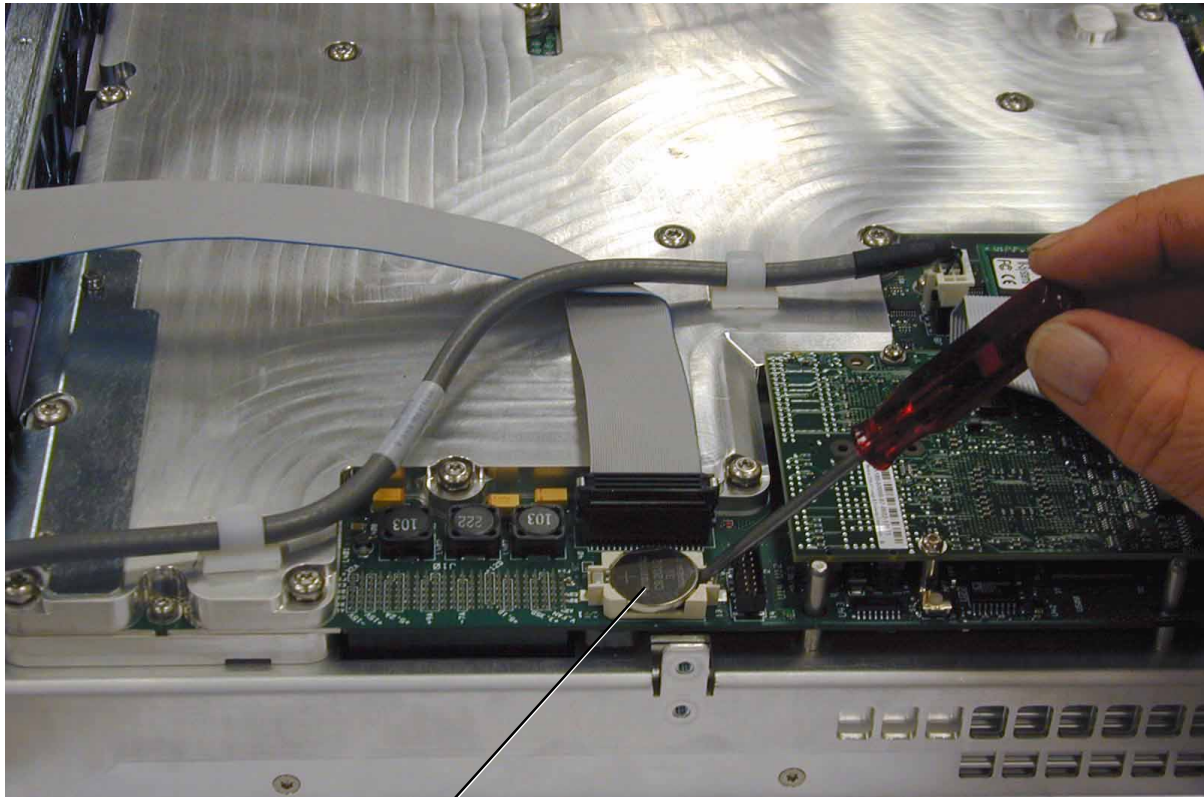

A3BT1

A4 Memory Chip

Tools Required

- T-10 driver

Removal Procedure

Refer to [Figure 2-20](#) for this procedure.

1. Disconnect the power cord.
2. Remove the covers from the signal generator. Refer to ["Outer Cover" on page 2-2](#) and ["Inner Bottom Cover" on page 2-6](#).
3. Place the signal generator flat and upside down with the rear panel facing you.
4. Using the T-10 driver, remove the screw (1) that attaches the A4 Memory Chip to the A3 RF Assembly.
5. Remove the A4 Memory Chip by gently rocking it side to side to release the pin.

Replacement Procedure

1. Reverse the order of the removal procedure.

CAUTION The A4 Memory Chip pin can be re-installed incorrectly. To insure proper installation, be sure to align the connector on the A4 Memory Chip with the connector on the A3 RF Assembly.

2. Torque all screws to 9 in-lbs.
3. Perform the post-repair performance tests that pertain to this replacement procedure, see [Chapter 4, Post Repair](#).

Figure 2-20 A4 Memory Chip

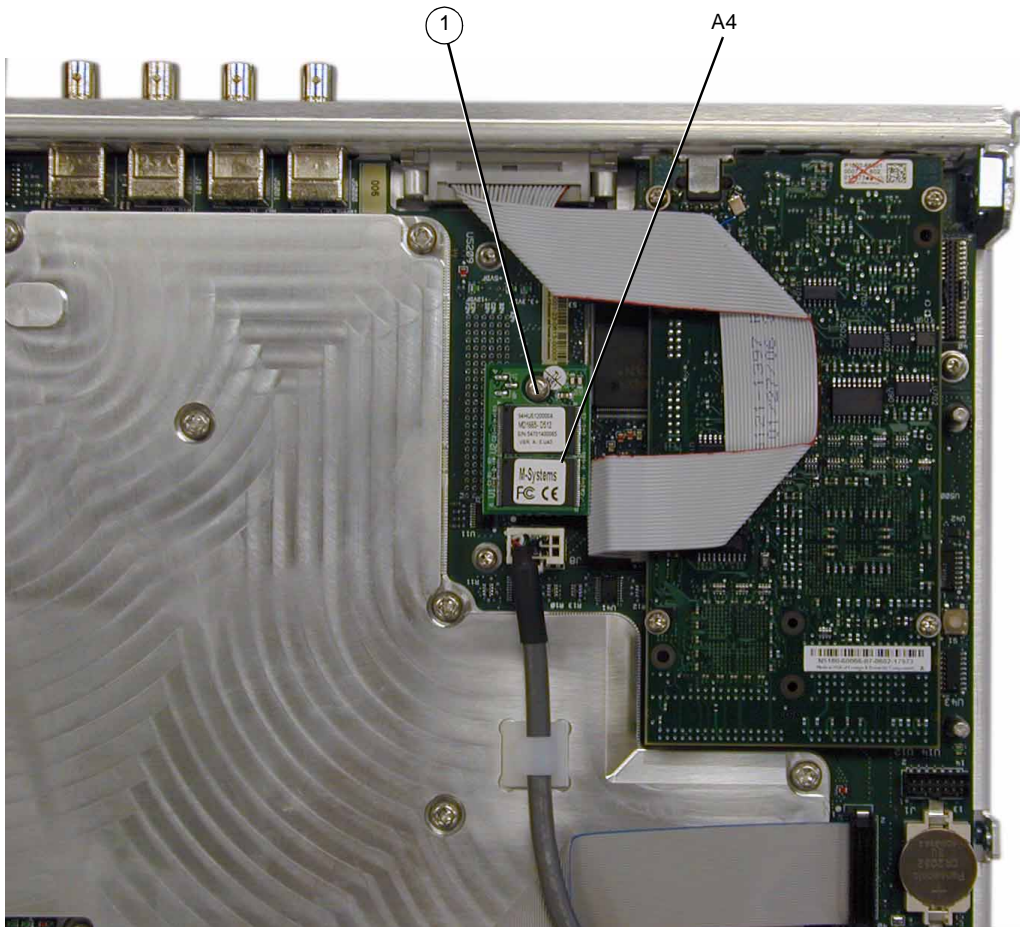

A5 CPU

Tools Required

- T-8 driver

Removal Procedure

Refer to [Figure 2-21](#) for this procedure.

CAUTION There are three pin connectors attaching the A5 CPU to the A3 RF Assembly. They are located on the short end of the A5 CPU board, closest to the front panel. Please use caution when removing the A5 CPU board.

1. Disconnect the power cord.
2. Remove the covers from the signal generator. Refer to ["Outer Cover" on page 2-2](#) and ["Inner Bottom Cover" on page 2-6](#).
3. Place the signal generator flat and upside down with the front panel facing you.
4. Using the T-8 driver, remove the four screws (1) that attach the A5 CPU to the A3 RF Assembly.
5. Remove the A5 CPU.
6. Disconnect W9.

Replacement Procedure

1. Reverse the order of the removal procedure.
2. Torque all screws to 9 in-lbs.
3. Perform the post-repair performance tests that pertain to this replacement procedure, see [Chapter 4, Post Repair](#).

Figure 2-21 A5 CPU

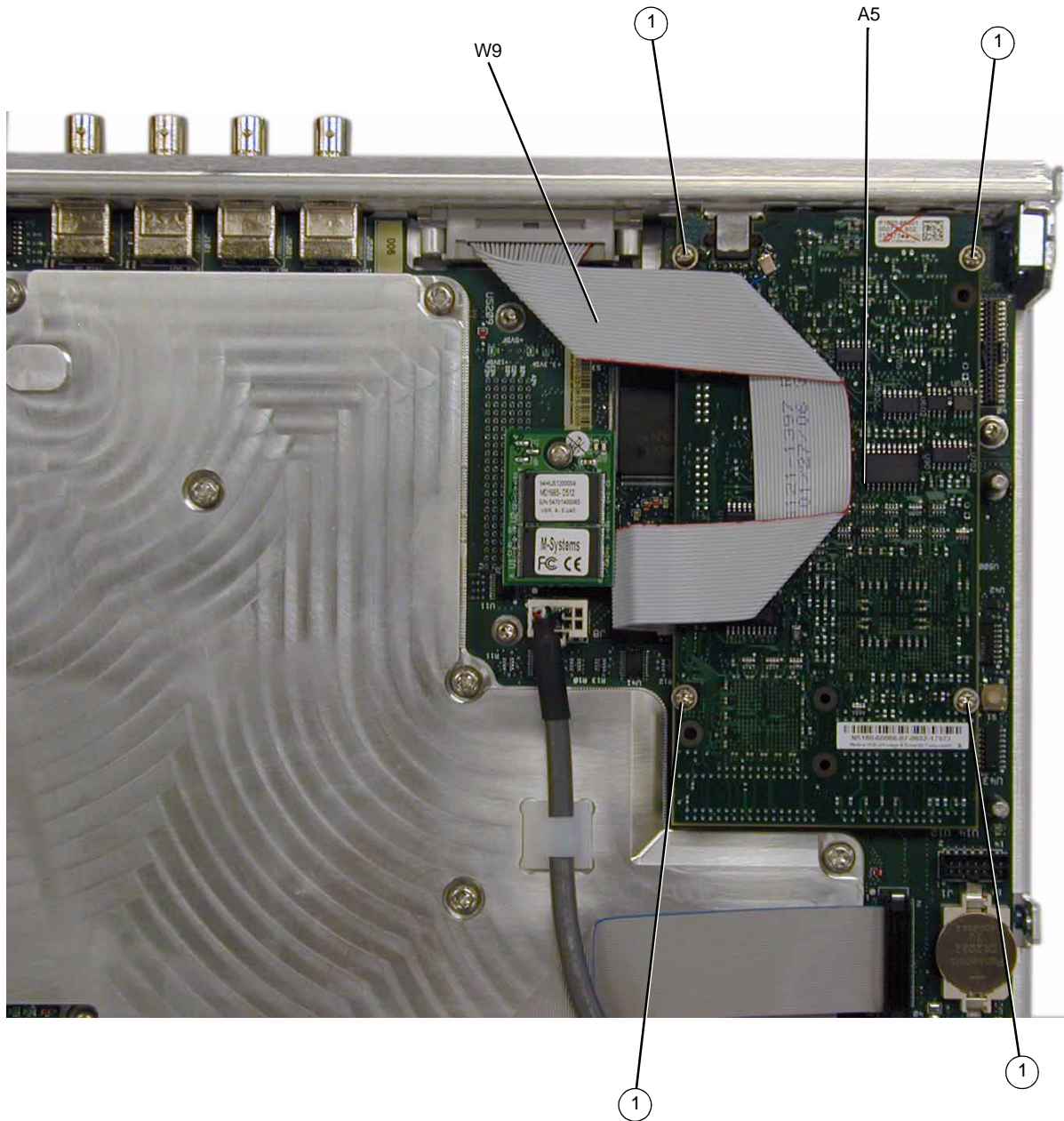

Rear Panel (N5181A)

Tools Required

- T-10 driver
- 5/8" hex-nut driver

Removal Procedure

Refer to [Figure 2-22](#) for this procedure.

1. Disconnect the power cord.
2. Remove the covers from the signal generator. Refer to "[Outer Cover](#)" on page 2-2, "[Inner Top Cover](#)" on page 2-4, and "[Inner Bottom Cover](#)" on page 2-6.
3. Position the signal generator flat and upside down with the rear panel facing you.
4. Using the 5/8" hex-nut driver, remove the eight nuts and washers (1) securing the A3 RF Assembly BNC's to the rear panel.
5. Using the T-10 driver, remove the four screws (2) securing the rear panel to the signal generators chassis.
6. Pull the rear panel away from the signal generator's chassis.

Replacement Procedure

1. Reverse the order of the removal procedure.
2. Torque all screws to 9 in-lbs.
3. Torque all BNC connectors to 8 in-lbs.
4. Perform the post-repair performance tests that pertain to this replacement procedure, see [Chapter 4, Post Repair](#).

Figure 2-22 Disassembled Rear Panel View

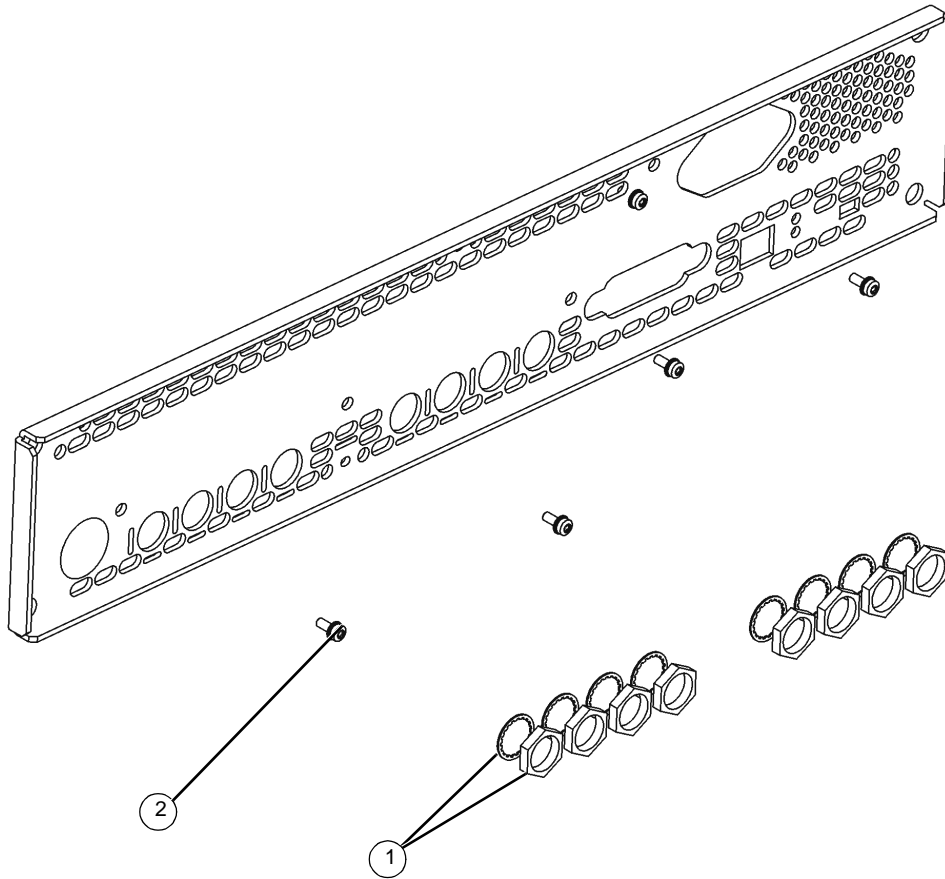

Rear Panel (N5182A)

Tools Required

- T-10 driver
- 5/8" hex-nut driver
- small Phillips screwdriver

Removal Procedure

Refer to [Figure 2-23](#) for this procedure.

1. Disconnect the power cord.
2. Remove the covers from the signal generator. Refer to "[Outer Cover](#)" on page 2-2, "[Inner Top Cover](#)" on page 2-4, and "[Inner Bottom Cover](#)" on page 2-6.
3. Position the signal generator flat and upside down with the rear panel facing you.
4. Using the 5/8" hex-nut driver, remove the fifteen nuts and washers (1) securing the A2 Vector Modulation Assembly and A3 RF Assembly BNC's to the rear panel.
5. Using the T-10 driver, remove the ten screws (2) securing the rear panel to the signal generators chassis.
6. Using a small Phillips screwdriver, remove the four Phillips screws (3) securing the A2 Vector Modulation Assembly connectors to the rear panel.
7. Pull the rear panel away from the signal generator's chassis.

Replacement Procedure

1. Reverse the order of the removal procedure.
2. Torque all screws to 9 in-lbs.
3. Torque all BNC connectors to 8 in-lbs.
4. Perform the post-repair performance tests that pertain to this replacement procedure, see [Chapter 4, Post Repair](#).

Figure 2-23 Disassembled Rear Panel View

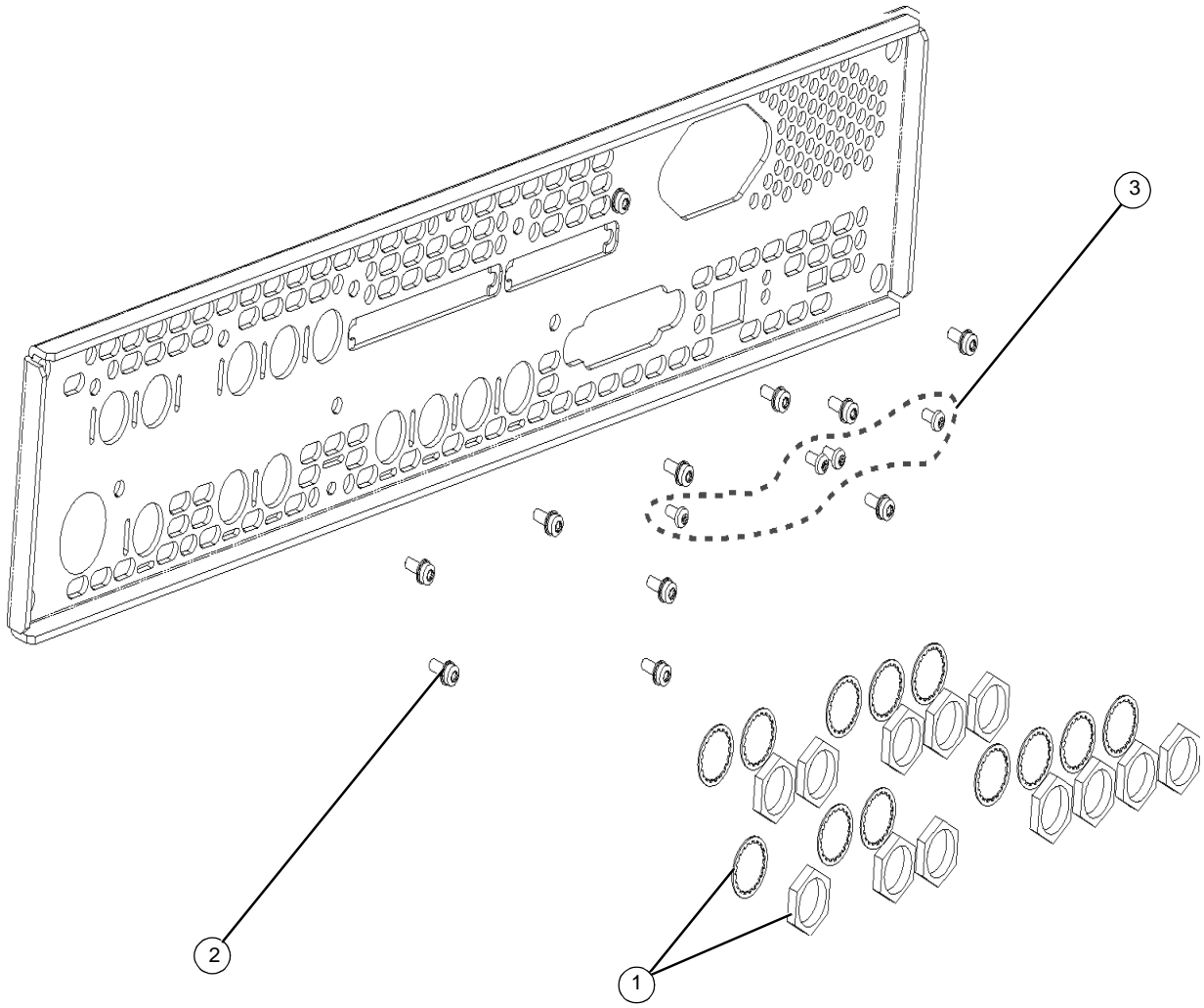

B1 thru B4 Fans

Tools Required

- T-10 driver
- T-20 driver
- needle-nose pliers

Removal Procedure

Refer to [Figure 2-24](#) and [Figure 2-25](#) for this procedure.

1. Disconnect the power cord.
2. Remove the covers from the signal generator. Refer to "Outer Cover" on page 2-2, "Inner Top Cover" on page 2-4, and "Inner Bottom Cover" on page 2-6.

NOTE If you are replacing the B1 Fan remove the A1 Power Supply, refer to "A1 Power Supply" on page 2-22.

3. Position the signal generator flat, with the A2 Vector Modulation Assembly facing up and the front panel facing you.
4. Using the T-10 driver, press the connector latch to disconnect the fan cable (1) from the A2 Power Supply.
5. Use the T-20 driver to push the rivet (2) out until you can remove it by pulling on it with your fingers.
6. Remove the fan, releasing the fan cable from the cable clips.

Replacement Procedure

1. Reverse the order of the removal procedure.

NOTE To re-install the rivets, use the needle-nose pliers to depress the rivet tip before inserting it into the chassis hole.

2. Perform the post-repair performance tests that pertain to this replacement procedure, see [Chapter 4, Post Repair](#).

Figure 2-24 B1 thru B4 Fans (1 of 2)

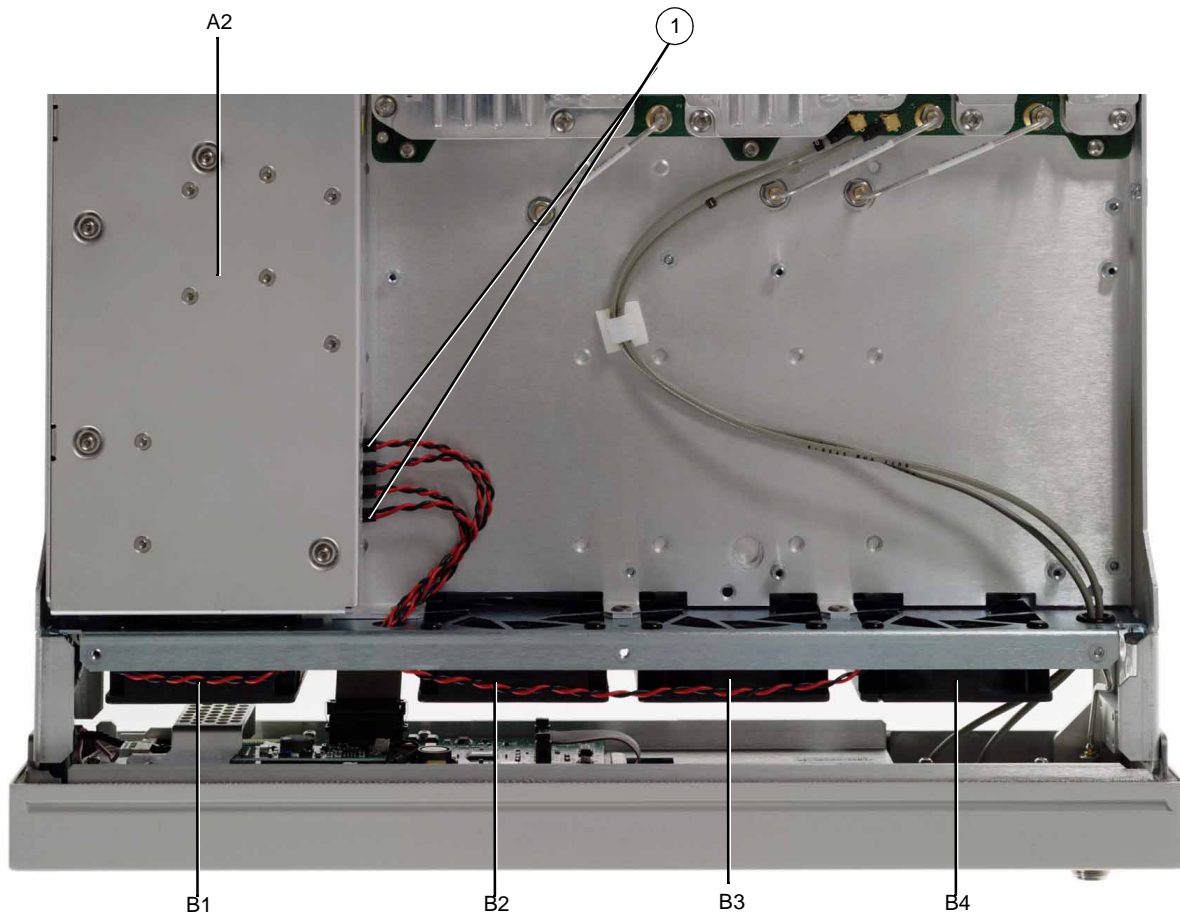
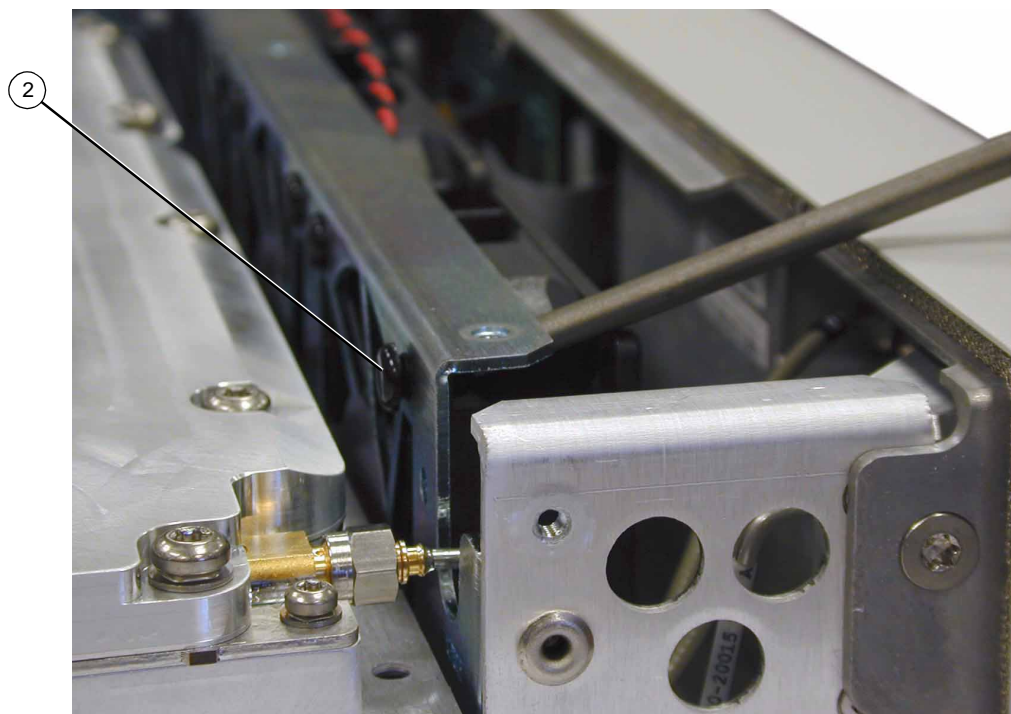
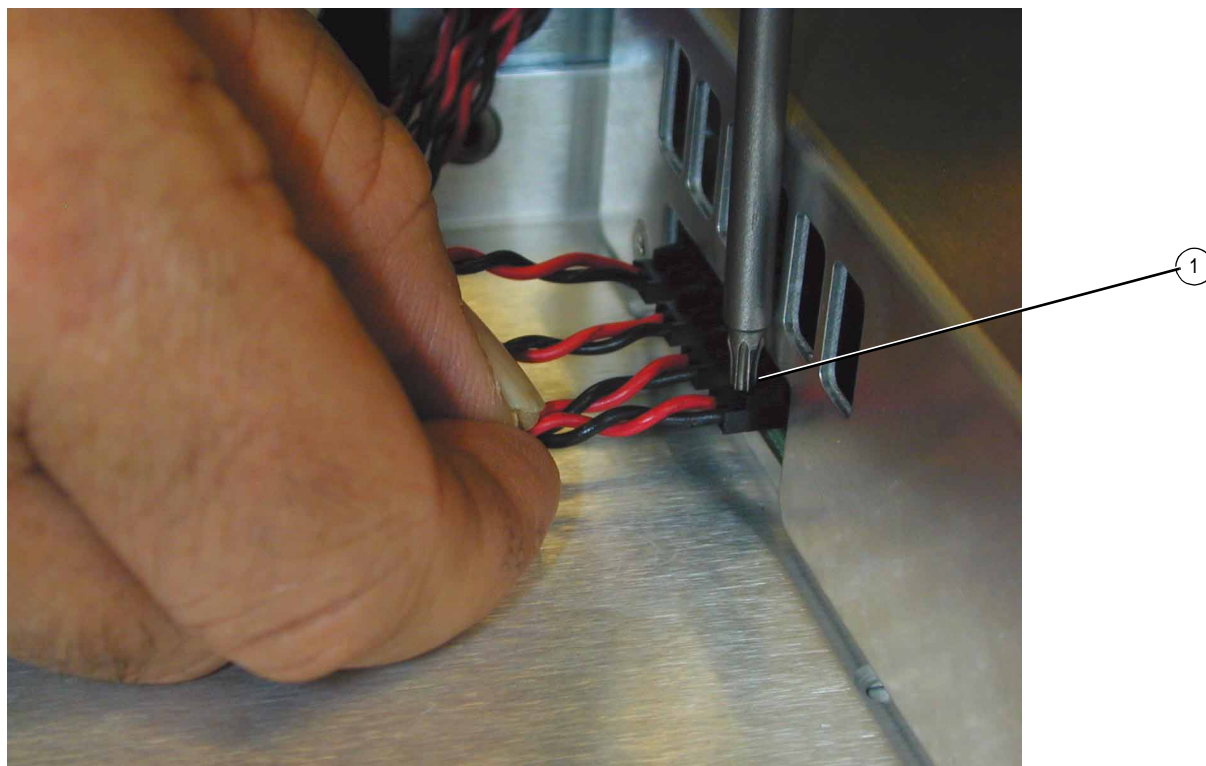

Figure 2-25 B1 thru B4 Fans (2 of 2)



3 Replaceable Parts

Ordering Information

To order a part, do the following:

1. Determine the part number.
2. Determine the quantity required.
3. Mail this information to the nearest Agilent Technologies office or, in the U.S., call the hot-line number listed in the following section.

To order a part not listed in the replaceable parts lists, mail the following information to the nearest Agilent Technologies office.

1. the instrument model number
2. the serial number and options, if any (see rear panel)
3. a description of the part
4. a description of the part's function
5. the quantity required

Order Parts Fast

When you have gathered the information required to place an order, go to the Agilent Technologies Technical Support website:

<http://www.agilent.com/find/techsupport>

Shipping a Defective Assembly Back to Agilent Technologies

1. When you receive the rebuilt/exchange assembly, be careful not to damage the box and shipping hardware in which it was shipped. You will use that box and shipping hardware to return the defective assembly. The box you receive should contain the following:
 - the rebuilt assembly
 - an exchange assembly failure report
 - a return address label
2. Complete the failure report.
3. Place the failure report and the defective assembly in the box. Be sure to remove the enclosed return address label.
4. Seal the box with tape.

If you are inside the United States, stick the pre-printed return address label over the label that is already on the box and return the box to Agilent Technologies. (Agilent Technologies pays postage on boxes mailed within the United States.)

If you are outside the United States, do not use the return address label; instead, address the box to the nearest Agilent Technologies sales and service office.

Frequency and Hardware Options

This section lists the options available with the Agilent N5181A/82A MXG Signal Generators.

Frequency Options	
501	250 kHz to 1 GHz frequency range (N5181A only)
503	250 kHz to 3 GHz frequency range
506	250 kHz to 6 GHz frequency range

Hardware Options	
1EM	Moves RF connector to the rear panel

Assemblies and Hardware Options

Description	Option 501/503		Option 506	
	Part Number	Page Number	Part Number	Page Number
Front Panel- N5181A (Analog) Option 501 Option 503	N5180-60018 N5180-60019		N5180-60020	
Front Panel - N5182A (Vector)	N5180-60016		N5180-60017	
Key Pad	N5180-60021		N5180-60021	
Power Switch	N5180-60022		N5180-60022	
Tested USB Board	N5180-60023		N5180-60023	
LCD	N5180-60024		N5180-60024	
AC-DC Inverter	N5180-60025		N5180-60025	
A1 Power Supply	0950-4651		0950-4651	
A2 Vector Modulation Assembly	N5180-60006		N5180-60006	
A3 RF Assembly UNM	N5180-69007		N5180-69009	
A3 RF Assembly UNM with UNU and/or UNT	N5180-69007		N5180-69009	
A3 RF Assembly UNM with UNU and/or UNT & any combination or all of the following options; UNV, UNZ, and 1EQ	N5180-69008		N5180-69010	
A3 RF Assembly 1EM	N5180-69011		N5180-69013	
A3 RF Assembly 1EM with UNU and/or UNT	N5180-69011		N5180-69013	
A3 RF Assembly 1EM with UNU and/or UNT & any combination or all of the following options; UNV, UNZ, and 1EQ	N5180-69012		N5180-69014	
A3BT1 Lithium Battery	1420-0356		1420-0356	
A4 Memory Chip	N/A		1819-0068	
A5 CPU	P1001-66501		P1001-66501	
B1 thru B4 Fan Kit (x4)	N5180-6xxxx		N5180-6xxxx	

Rear Panel - N5181A (Analog)	N5180-00002		N5180-00002	
Rear Panel - N5182A (Vector)	N5180-00001		N5180-00001	

Assemblies from a Top View

Figure 3-1 Assemblies from a Top View



Assemblies from a Bottom View

Figure 3-2 Assemblies from a Bottom View



Service Kits

N5181A Option UNM - N5180-xxxxx

Contents	Quantity
Key Pad Assembly	1
Power Switch Assembly	1
Tested USB Board	1
LCD Assembly	1
AC-DC Inverter Assembly	1
A1 Power Supply	1
A3 RF Assembly (Option UNM)	1
A3BT1 Lithium Battery	1
A5 CPU	1
B1 thru B4 Fan's	4
Analog Rear Panel	1
Plug-Hole 0.750-IN-DIA-HOLE	1
Assorted Screws/Washers/Nuts	TBD
BNC socket	1
TX8	1
TX10	1
TX15	1
TX20	1
X100 Phillips Screwdriver	1

N5182A Option UNM - N5180-xxxxx

Contents	Quantity
Key Pad Assembly	1
Power Switch Assembly	1
Tested USB Board	1
LCD Assembly	1
AC-DC Inverter Assembly	1
A1 Power Supply	1
A2 Vector Modulation	1
A3 RF Assembly (Option UNM)	1
A3BT1 Lithium Battery	1
A4 Memory Chip	1

A5 CPU	1
B1 thru B4 Fan's	4
Digital Rear Panel	1
Plug-Hole 0.750-IN-DIA-HOLE	1
BNC Cables	2
Assorted Screws/Washers/Nuts	TBD
BNC socket	1
TX8	1
TX10	1
TX15	1
TX20	1
X100 Phillips Screwdriver	1

N5181A Option 1EM - N5180-xxxxx

Contents	Quantity
Key Pad Assembly	1
Power Switch Assembly	1
Tested USB Board	1
LCD Assembly	1
AC-DC Inverter Assembly	1
A1 Power Supply	1
A3 RF Assembly (Option 1EM)	1
A3BT1 Lithium Battery	1
A5 CPU	1
B1 thru B4 Fan's	4
Analog Rear Panel	1
Plug-Hole 0.750-IN- DIA- HOLE	1
Assorted Screws/Washers/Nuts	TBD
BNC socket	1
TX8	1
TX10	1
TX15	1
TX20	1
X100 Phillips Screwdriver	1

N5182A Option 1EM - N5180-xxxxx

Contents	Quantity
Key Pad Assembly	1
Power Switch Assembly	1
Tested USB Board	1
LCD Assembly	1
AC-DC Inverter Assembly	1
A1 Power Supply	1
A2 Vector Modulation	1
A3 RF Assembly (Option 1EM)	1
A3BT1 Lithium Battery	1
A4 Memory Chip	1
A5 CPU	1
B1 thru B4 Fan's	4

Digital Rear Panel	1
Plug-Hole 0.750-IN-DIA-HOLE	1
BNC Cables	2
Assorted Screws/Washers/Nuts	TBD
BNC socket	1
TX8	1
TX10	1
TX15	1
TX20	1
X100 Phillips Screwdriver	1

Cables

This section lists part numbers for the cables in your signal generator.

Table 3-1

Reference Designator	Input	Output	Part Number	Page Number
B1W1 ^a	Wire Cable, B1 Fan	A1 Power Supply	(part of B1)	3-11
B2W1 ^a	Wire Cable, B2 Fan	A1 Power Supply	(part of B2)	3-11
B3W1 ^a	Wire Cable, B3 Fan	A1 Power Supply	(part of B3)	3-11
B4W1 ^a	Wire Cable, B4 Fan	A1 Power Supply	(part of B4)	3-11
W1	A1 Front Panel (USB)	A3 RF Assembly	8121-1396	3-12
W2	Ribbon Cable, Front Panel	A3 RF Assembly	8121-1398	3-12
W3 (N5182A only)	A1 Front Panel (I Input)	A2J15	8121-0642	3-11
W4 (N5182A only)	A1 Front Panel (Q Input)	A2J16	8121-0642	3-11
W5 (N5182A only)	Semi-Rigid Cable, A3 RF Assembly	A2 Vector Modulation	N5180-20016	3-11
W6 (N5182A only)	Semi-Rigid Cable, A3 RF Assembly	A2 Vector Modulation	N5180-20025	3-11
W7 (N5182A only)	Semi-Rigid Cable, A3 RF Assembly	A2 Vector Modulation	N5180-20026	3-11
W8	Ribbon Cable, A3 RF Assembly (GPIB)	A5 CPU	8121-1397	3-12

^aThis cable is not replaceable by itself. You must order the corresponding assembly.

Cables from a Top View

Figure 3-3 Cables from a Top View

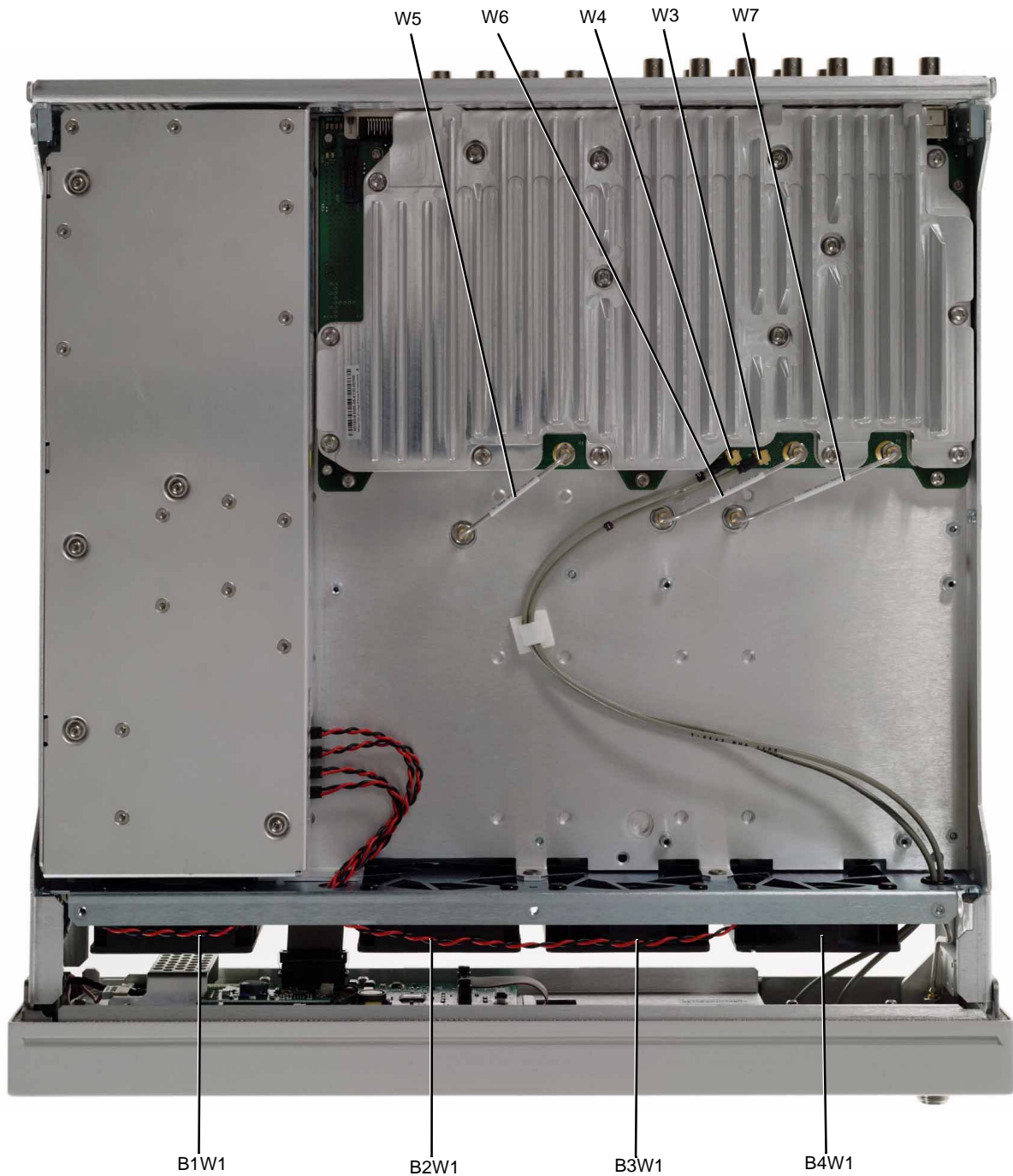

Cables from a Bottom View

Figure 3-4 Cables from a Bottom View



Hardware

This section lists part numbers for hardware and other instrument parts in your signal generator.

- “Front Panel View” on page 3-13
- “Disassembled Rear Panel View” on page 3-14
- “Main Chassis with Inside Covers” on page 3-15
- “Outer Instrument Cover and Associated Parts” on page 3-17

Front Panel View

Table 3-2 Front Panel View

Item No.	Description	Qty	Part Number
1	Small Overlay	1	N5180-80003
2	Nameplate	1	N5180-80004
3	RPG Knob	1	W1312-40017
4	Large Keypad Overlay	1	N5180-80001
5	Washer-Wavy .490ID (N5182A only)	2	2190-0102
6	Nut-Hex 15/32-32 (N5182A only)	2	2950-0035

Figure 3-5 Front Panel View



Disassembled Rear Panel View

Table 3-3 Disassembled Rear Panel View

Item No.	Description	Qty	Part Number
1	Rear Panel	1	N5180-00001
2	Screw-Machine M3.0 8 CW-PN-TX N5181A N5182A	4 10	0515-0372
3	Screw-Machine 4-40 (N5182A only)	4	2200-0139
4	Washer Lock .505ID (BNC connectors on rear-panel) N5181A N5182A	8 15	2190-0068
5	Nut-Hex 1/2-28 (BNC connectors on rear-panel board) N5181A N5182A	8 15	2950-0054
6	Rear-Panel BNC Hole Plug	1	6960-0517

Figure 3-6 Disassembled Rear Panel View

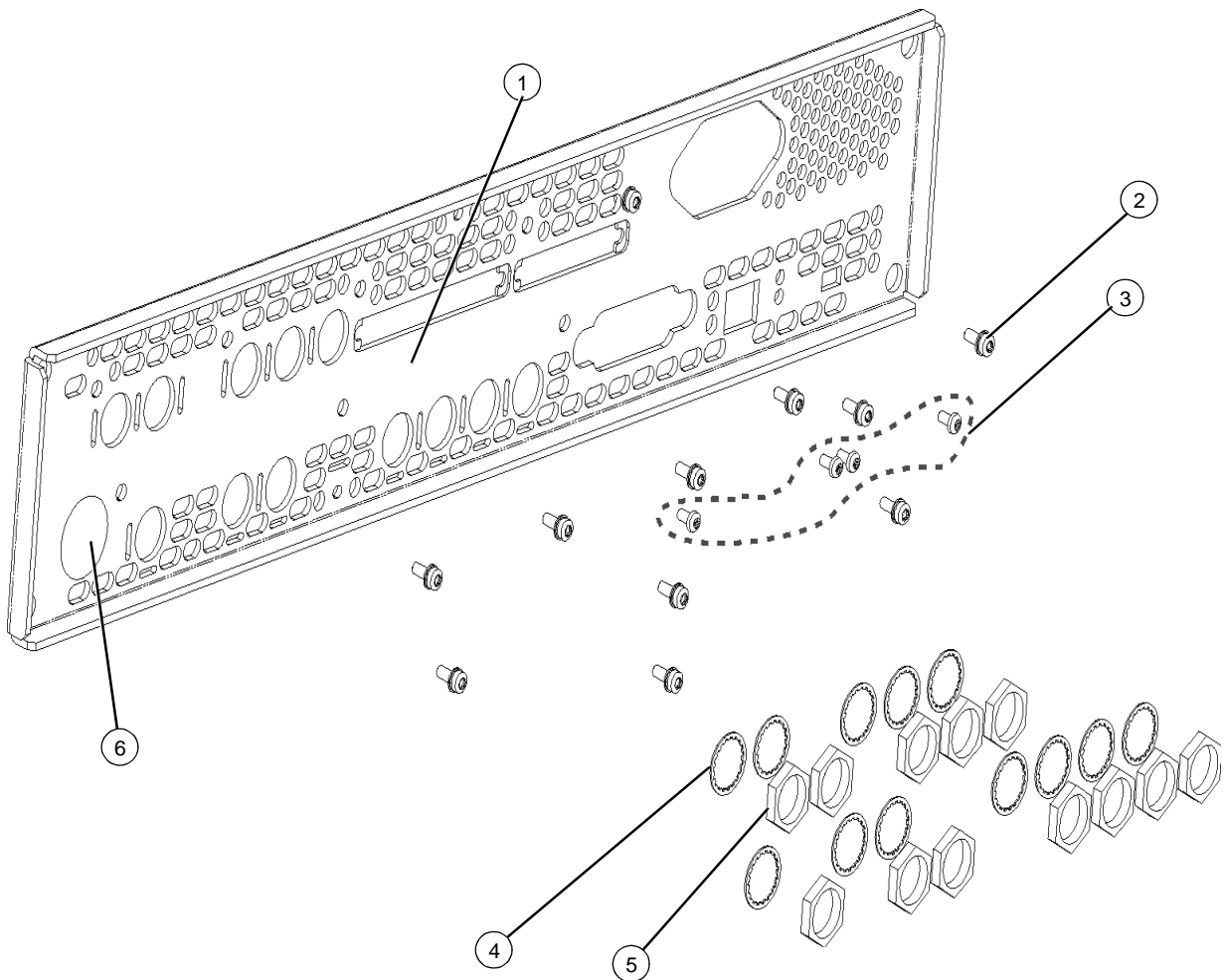

Main Chassis with Inside Covers

Table 3-4 Main Chassis with Inside Covers

Item No.	Description	Qty	Part Number
1	Main Chassis Inside Top Cover	1	W1312-00019
2	Main Chassis Inside Bottom Cover	1	W1312-00020
3	Screw-Machine M3.0 x 08 FL-TX (inside top and bottom covers to main chassis)	24	0515-1227
4	Screw-Machine M3.0 x 08 CW-PN-TX (inside top and bottom covers to rear panel)	2	0515-0372
6	Main Chassis	1	N5180-60009

Figure 3-7 Main Chassis with Inside Covers

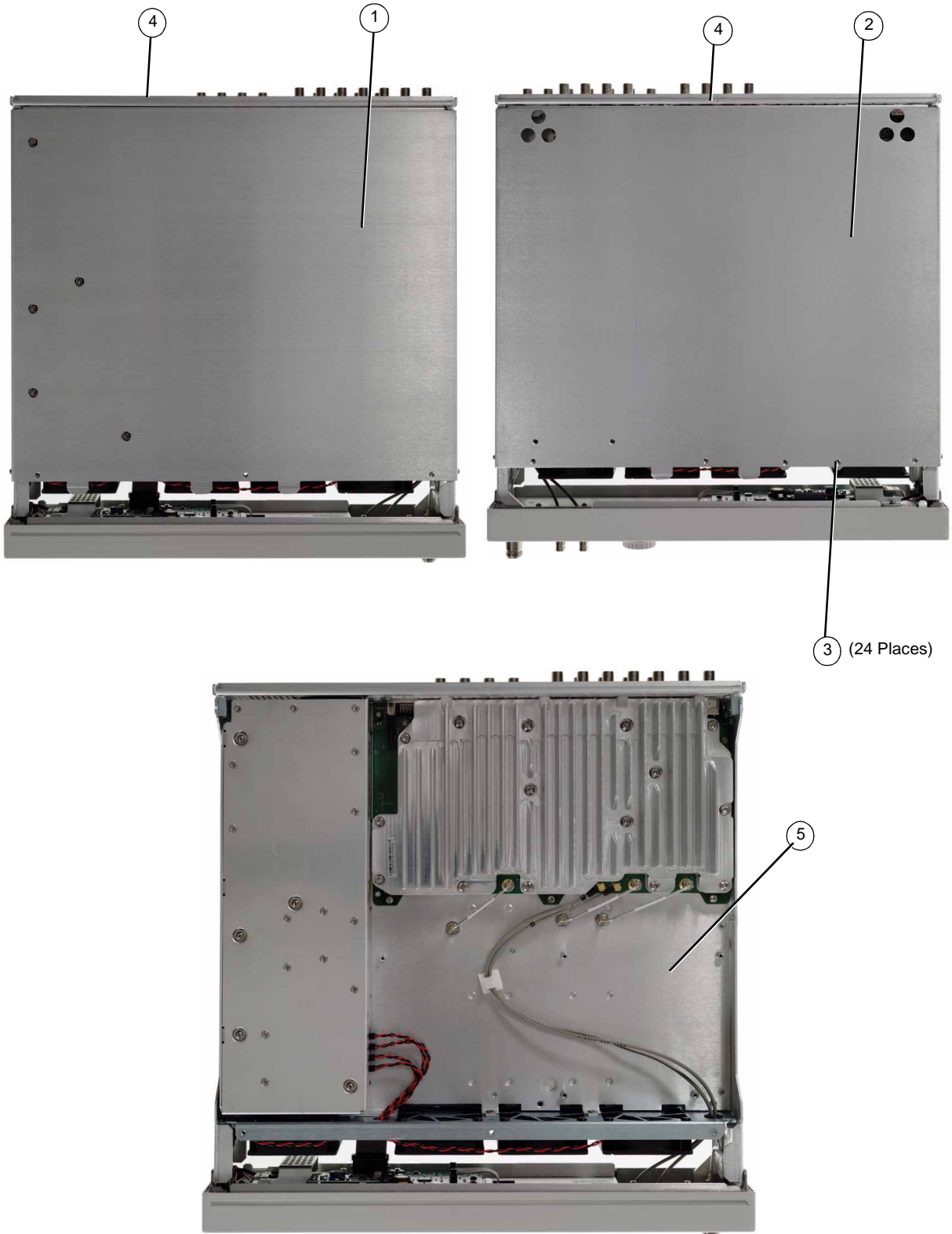

Outer Instrument Cover and Associated Parts

Table 3-5 Outer Instrument Cover and Associated Parts

Item No.	Description	Qty	Part Number
1	Assy-Strap Handle - includes the following parts:	1	E4400-60026
	Strap Assembly	1	
	Ground Spring	2	
	Handle Retainer	2	
	End Cap	2	
	Screw-Machine M5 x 18 FL-TX	2	
2	Hole Plug (not shown in photo)	2	W1312-40024
3	Screw-Machine M5 x 0.8 12mm-lg (not shown in photo)	2	0515-0708
4	Rear Feet Screws (not shown in photo)	4	0515-1619
5	Rear-Panel Feet	4	5041-9611
6	Feet-Bottom	4	5041-9167
7	Tilt Stand	2	1460-1345
8	Outside Instrument Cover	1	W1312-00018

Figure 3-8 Outer Instrument Cover and Associated Parts



Miscellaneous

This section lists part numbers for miscellaneous items that can be used with your signal generator.

Documentation

Table 3-6 Documentation

Description	Part Number
Documentation Set	N5180-90001
CD-ROM Documentation	N5180-90007
Installation Guide	N5180-90002
User's Guide	N5180-90003
SCPI Command Reference	N5180-90004
Programming Guide	N5180-90005
Service Guide	N5180-90006
Specifications/Data Sheet (N5181A)	5989-5311EN
Specifications/Data Sheet (N5182A)	5989-5261EN

NOTE The N5181A/82A MXG documentation can also be found on the web at <http://www.agilent.com/find/mxg>.

Electrostatic Discharge (ESD) Protective Supplies

Table 3-7 Electrostatic Discharge (ESD) Protective Supplies

Description	Part Number
ESD connector end cap front-panel RF output	1401-0247
ESD connector end cap rear panel SMI	1252-4690
ESD connector end cap-GPIB	1252-5007
ESD connector end cap coherent carrier cut	1252-4696
2 X 4 Ft. Antistatic Table Mat with 15 FT. Ground Wire	9300-0797
5 Ft. Grounding Cord (for wrist strap)	9300-0980
Adjustable Antistatic Wrist Strap	9300-1367

Abbreviations Used in Part Descriptions

This section defines the reference designators, abbreviations, and option numbers that are used in the part descriptions throughout this chapter.

Reference Designator	Definition
A	assembly
AT	attenuator
B	fan
DS	lamp
J	electrical connector; jack
W	cable; transmission path; wire

Abbreviation	Definition
BN	buttonhead (screws)
CPU	central processing unit
CW	conical washer (screws)
EXT	external
FL	flathead (screws)
Ft	feet
Hex	hexagonal
GPIB	general purpose interface bus
HX	hexagonal recess (screws)
I	in-phase
LF	low frequency
M	meters or metric hardware
PC	patch lock (screws) or printed circuit
PN	panhead (screws)
Q	quadrature
Qty	quantity
RF	radio frequency
RPP	reverse power protection
SMA	subminiature type-A
TX	TORX recess (screws)

4 Post Repair

Operation verification is a series of tests used to confirm that the signal generator is operating properly, or to diagnose problems. Operation verification does not verify performance to instrument specifications.

Perform operation verification when you initially set up the signal generator, after a minor repair or when the integrity of the signal generator is in question.

- [Running Self Test](#) on page 1
- [Frequency Range and Accuracy Check](#) on page 3
- [Checking the Output Power](#) on page 6

Running Self Test

Self Test is a series of internal tests of signal generator functions. If this test fails, refer to [“Self Test Failure”](#) on page 2 for further instructions.

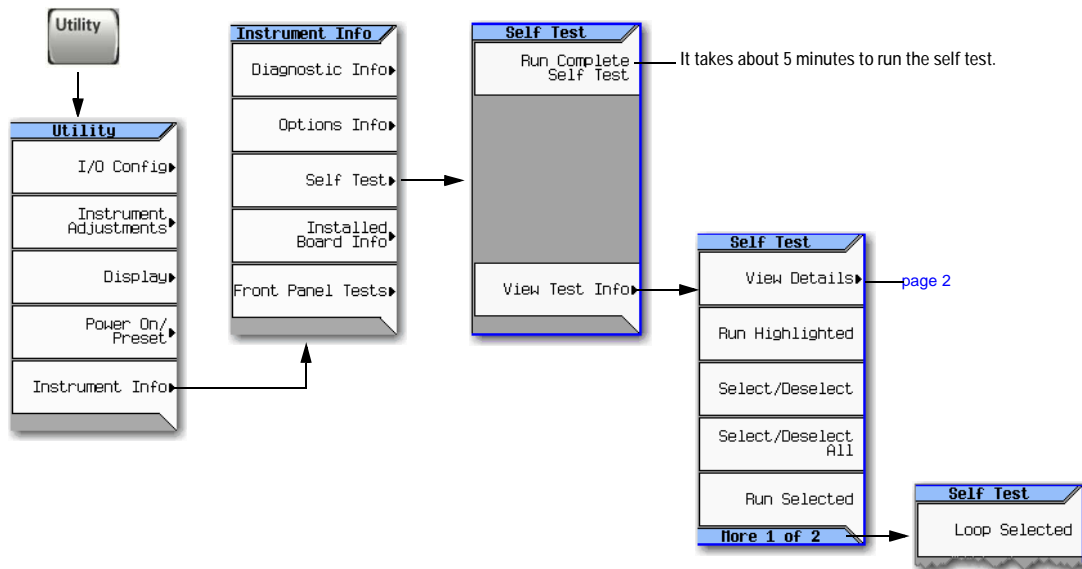

Use the following procedure to run self test:

1. Disconnect all external cables, including GPIB, LAN, and USB cables.
2. Preset the signal generator: Press **Preset** > **Utility** > **Instrument Info** > **Self Test**.

The following message appears:

- The current status of the self-test is: Incomplete. Not all tests have been run.

3. Press **Run Complete Self Test**.

An activity bar displays on the screen indicating the test progress.

If you press **Abort** while self-test is running, the following message displays:

- The current status of the self-test is: Incomplete. Not all tests have been run.

When self-test completes, one of the following messages displays:

- The current status of the self-test is: Passed
- The current status of the self-test is: Failure. One or more tests have failed. System diagnostics indicate this test as the root failure: xxx

If the signal generator fails only one test, the title of the failed test displays. If the signal generator fails more than one test, the test number of the most significant failure displays.

Self Test Failure

1. Confirm that all external cables, including GPIB, LAN, and USB cables, are disconnected from the signal generator and repeat the self-test.
2. If the self-test continues to fail, the signal generator requires service. If you are unable to service the signal generator, send it to an Agilent service center for repair. Include a detailed description of the failed test(s) and any displayed error messages.

See “Viewing Test Results” on page 2 for information about viewing detailed self test results.

See “Returning a Signal Generator to Agilent Technologies” on page 16 for return instructions.

Viewing Test Results

Utility > Instrument Info > Self Test >

If Self Test fails, the summary indicates the probable cause.

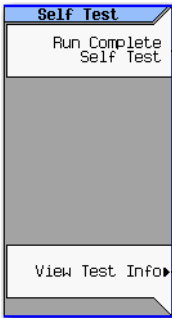
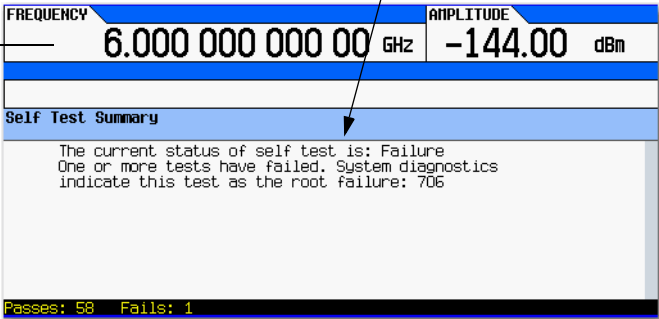
The current status of self test is: Failure
One or more tests have failed. System diagnostics indicate this test as the root failure: 706

Passes: 58 Fails: 1

Use the arrow keys to highlight the desired test and press View Details.

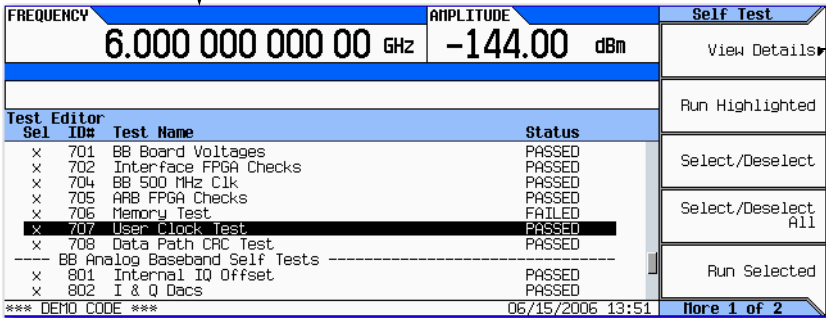

Test Editor Sel	ID#	Test Name	Status
x	701	BB Board Voltages	PASSED
x	702	Interface FPGA Checks	PASSED
x	704	BB 500 MHz Clk	PASSED
x	705	AFB FPGA Checks	PASSED
x	706	Memory Test	FAILED
x	707	User Clock Test	PASSED
x	708	Data Path CRC Test	PASSED
----- BB Analog Baseband Self Tests -----			
x	801	Internal IQ Offset	PASSED
x	802	I & Q Dacs	PASSED

*** DEMO CODE *** 06/15/2006 13:51 Home 1 of 2

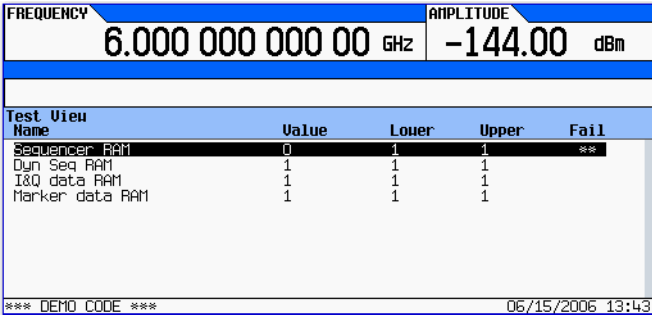

Test View Name	Value	Lower	Upper	Fail
Sequencer RAM	0	1	1	**
Dyn Seq RAM	1	1	1	
I&Q data RAM	1	1	1	
Marker data RAM	1	1	1	

*** DEMO CODE *** 06/15/2006 13:43

Frequency Range and Accuracy Check

The frequency range is tested by determining the frequency accuracy relative to the timebase at the frequency limits of the signal generator. This test can be performed with either a frequency counter or a spectrum analyzer.

Table 4-1 Recommended Equipment for Checking N5181A/82A Frequency Range and Accuracy

Test Equipment	Recommended Model
Frequency Counter	Agilent 53131A or 53132A frequency counter with option 010 and 050 or 124
Spectrum Analyzer	Agilent E4440A PSA Series spectrum analyzer

Frequency Counter Procedure

1. Connect the equipment as shown.

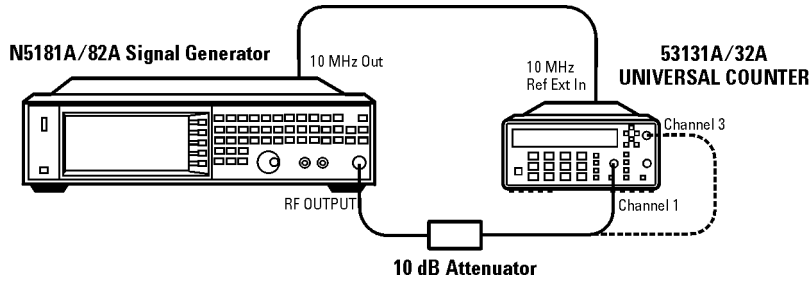

2. Preset the signal generator: Press Preset.
3. Turn modulation off: Press the Mod On/Off so that the MOD On/Off LED turns off.
4. Set the amplitude: Press Amplitude and enter 0 dBm.
5. Turn RF on: Press RF On/Off so that the RF On/Off LED lights.
6. Verify that the frequency counter is locked to the 10 MHz external reference frequency (± 1 Hz).
7. For maximum accuracy, set the gate time on the frequency counter to > 5 seconds. (Press Gate & ExtArm twice and use the arrow keys to set the value.)
8. Set the frequency: Press Frequency and set the signal generator to the first frequency listed in [Table 4-2](#).
9. Confirm that the measured frequency is within the limits listed.
10. Repeat step 8 and step 9 for all of the frequencies in the table that are within the frequency range of your signal generator.

NOTE For frequencies < 200 MHz, use Channel 3 on the frequency counter (press Freq Ratio until CH3: displays).

Table 4-2 Frequency Accuracy Limits

Frequency (MHz)	Limit (Hz)
0.25 MHz	± 1
0.5 MHz	± 1
1 MHz	± 1
10 MHz	± 1
50 MHz	± 1
100 MHz	± 1
500 MHz	± 1
800 MHz	± 1
1000 MHz	± 1
2000 MHz	± 1
3100 MHz	± 1
4000 MHz	± 1
5000 MHz	± 1
6000 MHz	± 1

Spectrum Analyzer Procedure

1. Connect the equipment as shown.

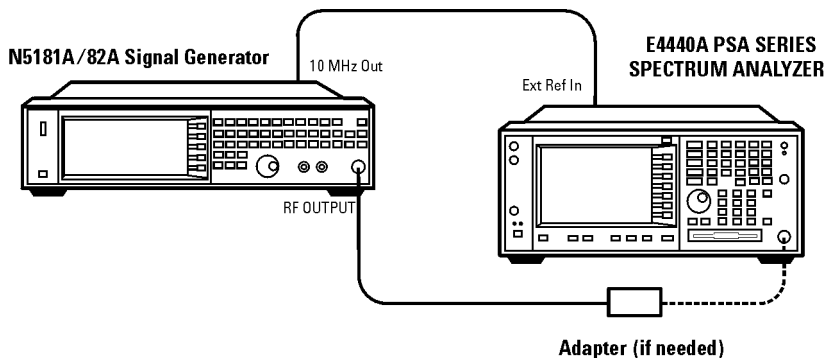

2. Verify that the spectrum analyzer is locked to the 10 MHz external reference frequency.
3. Align the spectrum analyzer: Press **System** > **Alignment** > **Align All Now**.
4. Preset the signal generator: Press **Preset**.
5. Turn modulation off: Press the **Mod On/Off** so that the MOD On/Off LED turns off.
6. Set the amplitude: Press **Amplitude** and enter 0 dBm.
7. Turn RF on: Press **RF On/Off** so that the RF On/Off LED lights.
8. Set the frequency: Press **Frequency** and set the signal generator to the first frequency listed in [Table 4-3](#).
9. Confirm that the measured frequency is within the limits listed in the table.
10. Repeat step 8 and step 9 for all of the frequencies in the table that are within the frequency range of your signal generator.

Table 4-3 Frequency Accuracy Limits

Frequency (MHz)	Limit (Hz)
0.25 MHz	±1
0.5 MHz	±1
1 MHz	±1
10 MHz	±1
50 MHz	±1
100 MHz	±1
500 MHz	±1
800 MHz	±1
1000 MHz	±1
2000 MHz	±1
3100 MHz	±1
4000 MHz	±1
5000 MHz	±1
6000 MHz	±1

Troubleshooting Problems with the Frequency Accuracy Check

- Verify the cables are connected correctly.
- If you are using a frequency counter, verify that you are using the correct channel for the frequencies you are measuring.
- If you are using a spectrum analyzer, verify that the spectrum analyzer is set to external reference.

Checking the Output Power

This test verifies that the CW output power from the signal generator is within defined limits. The following table lists the preferred equipment for this test.

Test Equipment	Recommended Model
Power Meter	Agilent E4418B or E4419A/B E-Series power meter
Power Sensor, Input: Type-N (m)	Agilent E9304A H19 power sensor

- [N5181A Test Procedure](#) on page 7
- [N5182A Test Procedure](#) on page 8

If this test fails, refer to [“Troubleshooting Problems with the Output Power Check”](#) on page 9 for further instructions.

N5181A Test Procedure

1. Zero and calibrate the power sensor to the power meter:

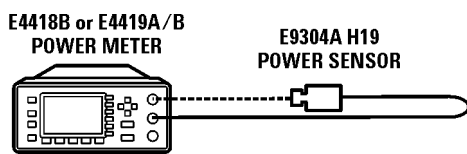

2. Connect the equipment as shown:

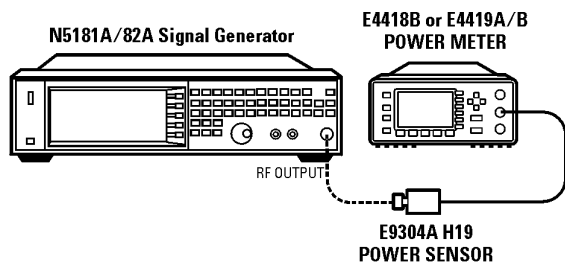

3. Preset the signal generator: Press Preset.
4. Turn RF on: Press RF On/Off so that the RF On/Off LED lights.
5. Turn modulation off: Press Mod On/Off so that the Mod On/Off LED turns off.
6. Set the frequency: Press Frequency and enter the first frequency value listed in [Table 4-4](#).
7. Set the amplitude: Press Amplitude and enter the amplitude value for that frequency.
8. Configure the power meter for the measurement.
 - a. Press the Frequency Cal Fac button on the power meter.
 - b. Select a power meter channel (if applicable).
 - c. Use the arrow keys to enter the frequency at which to measure the power.
9. Measure the output power level.
10. Repeat steps 6 through 9 to measure power at each of the 15 frequencies listed in [Table 4-4](#).
11. Confirm that the measured power levels are within the limits listed in the table.

Table 4-4 Levelled Output Power Limits

N5181A Output Power		
Frequency	Amplitude (dBm)	Limits (dB)
125 MHz	7	±1
275 MHz	7	±1
338 MHz	7	±1
425 MHz	7	±1
538 MHz	7	±1
675 MHz	7	±1
850 MHz	7	±1
1075 MHz	7	±1
1350 MHz	7	±1
1700 MHz	7	±1
2150 MHz	7	±1
2700 MHz	7	±1
3400 MHz	7	±1
4300 MHz	7	±1
5400 MHz	7	±1

NOTE Limit values are due to power meter uncertainty.

N5182A Test Procedure

Test Setup

1. Zero and calibrate the power sensor to the power meter:

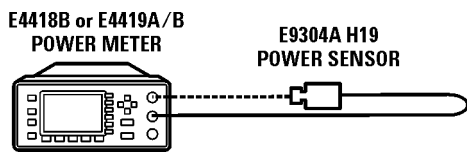

2. Connect the equipment as shown below:

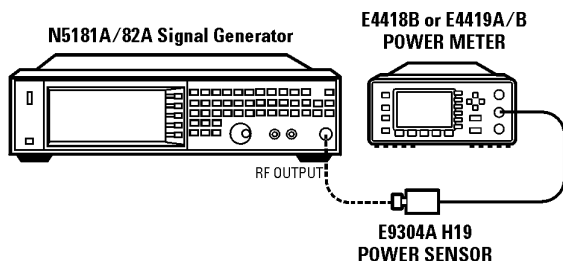

3. Preset the signal generator: Press Preset.
4. Turn RF on: Press RF On/Off so that the RF On/Off LED lights.
5. Turn modulation off:
Press Mod On/Off so that the Mod On/Off LED turns off.

Without Modulation

6. Set the signal generator frequency to the first value listed in [Table 4-6](#):
Press **Frequency > 125 > MHz**.
7. Set the amplitude to 7 dBm:
Press **Amplitude > 7 > dBm**.
8. Configure the power meter as follows:
 - a. On the power meter, press the **Frequency Cal Fac** button.
 - b. If applicable, select a power meter channel.
 - c. Use the arrow keys to enter the frequency at which to measure the power.
9. Measure the output power level.
10. Repeat steps 6 through 9 for the remaining frequencies in the table, and confirm that the power level at each point is within limits.

Table 4-5

N5182A Output Power without Modulation		
Frequency (MHz)	Amplitude (dBm)	Limits (dB)
250	7	±1
338	7	±1
425	7	±1
538	7	±1
675	7	±1
850	7	±1
1075	7	±1
1350	7	±1
1700	7	±1
2150	7	±1
2700	7	±1
3400	7	±1
4300	7	±1
5400	7	±1

With Modulation

11. Preset the signal generator: Press Preset.
12. Select the factory-supplied waveform SINE_TEST_WFM:
 - a. Press **Mode > Dual ARB > Select Waveform**.
 - b. Highlight the SINE_TEST_WFM waveform.
 - c. Press **Select Waveform**.
13. Turn the arbitrary waveform player on: Press the ARB softkey to highlight On.
14. Set the frequency to the first value listed in [Table 4-6](#):
Press **Frequency > 125 > MHz**.
15. Set the amplitude to 7 dBm:
Press **Amplitude > 7 > dBm**.
16. Configure the power meter as follows:
 - a. On the power meter, press the **Frequency Cal Fac** button.
 - b. Select a power meter channel (if applicable).
 - c. Use the arrow keys to enter the frequency at which to measure the power.
17. Measure the output power.

18. Repeat steps 14 through 17 for the remaining frequencies listed in Table 4-6, and confirm that the power level at each point is within limits.

Table 4-6

N5182A Output Power with Modulation		
Frequency (MHz)	Amplitude (dBm)	Limits (dB)
250	7	±1
323	7	±1
512	7	±1
814	7	±1
1275	7	±1
2025	7	±1
2750	7	±1
3750	7	±1
5250	7	±1

Troubleshooting Problems with the Output Power Check

- Verify that you are using the appropriate power sensor.
- Normally, power sensor calibration factors are automatically downloaded to the power meter when the power meter turns on. If this does not occur, manually enter the correct calibration factors for the power sensor you are using.
- Verify that the power sensor is properly calibrated to the power meter.

5 Safety and Regulatory

This chapter provides information on the following:

- “General Safety Considerations” on page 5-1
- “Lithium Battery Disposal” on page 5-2
- “Assistance” on page 5-2
- “Certification” on page 5-2

The following safety notes are used throughout this manual. Familiarize yourself with each of the notes and its meaning before operating this instrument.

WARNING **Warning denotes a hazard. It calls attention to a condition or situation that could result in personal injury or loss of life. Do not proceed beyond a warning until you fully understand the indicated conditions or situations.**

CAUTION **Caution calls attention to a condition or situation that could result in damage to or destruction of the signal generator, or in the loss of a user’s settings or data. Do not proceed beyond a caution until you fully understand the indicated conditions..**

General Safety Considerations

The following safety notes apply specifically to signal generators. These notes also appear in other chapters of this service guide as required.

WARNING **These servicing instructions are for use by qualified personal only. To avoid electrical shock, do not perform any servicing unless you are qualified to do so.**

WARNING **The opening of covers or removal of parts is likely to expose dangerous voltages. Disconnect the product from all voltage sources before starting to open.**

WARNING **The detachable power cord is the instrument disconnecting device. It disconnects the main circuits from the main supply before other parts of the instrument. The front panel switch is only a standby switch and is not a LINE switch (disconnecting device).**

WARNING **The power cord is connected to internal capacitors that may remain live for 5 seconds after disconnecting the plug from its power supply.**

WARNING **This is a Safety Class 1 Product (provided with a protective earthing ground incorporated in the power cord). The mains plug shall only be inserted in a socket outlet provided with a protective earth contact. Any interruption of the protective conductor inside or outside of the product is likely to make the product dangerous. Intentional interruption is prohibited.**

WARNING **Replace battery only with the same or equivalent type recommended. Discard used batteries according to manufacturer’s instructions.**

WARNING **If this product is not used as specified, the protection provided by the equipment could be impaired. This product must be used in a normal condition (in which all means for protection are intact) only.**

CAUTION **Many of the assemblies in this instrument are very susceptible to damage from electrostatic discharge (ESD). Perform service procedures only at a static-safe workstation and wear a grounding strap.**

Lithium Battery Disposal

When the battery on the A14 CPU is exhausted and/or ready for disposal, dispose of it according to your country's requirements. You can return the battery to your nearest Agilent Technologies Sales and Service office for disposal, if required.

Figure 5-1

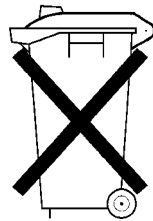

**DO NOT THROW BATTERIES AWAY BUT
COLLECT AS SMALL CHEMICAL WASTE.**

sk780a

Assistance

Product maintenance agreements and other customer assistance agreements are available for Agilent Technologies products. For any assistance, contact your nearest Agilent Technologies sales and service office.

Certification

Agilent Technologies Company certifies that this product met its published specifications at the time of shipment from the factory. Agilent Technologies further certifies that its calibration measurements are traceable to the United States National Institute of Standards and Technology, to the extent allowed by the Institute's calibration facility, and to the calibration facilities of other International Standards Organization members.

A

ac-dc inverter, replacement, [1-12](#)
antistatic materials, [2-19](#)
assemblies list, [2-2](#)
assembly replacement
 A1 Power Supply, [1-22](#)
 A2 Vector Modulation Assembly, [1-24](#)
 A3 RF Assembly, [1-26](#), [1-30](#)
 A3BT1 Battery, [1-34](#)
 A4 Memory Chip, [1-36](#)
 A5 CPU, [1-38](#)
 AC-DC Inverter, [1-12](#)
 B1 thru B4 Fan, [1-44](#)
 EMI Display with Gasket, [1-16](#)
 Front Panel, [1-8](#)
 Inner Bottom Cover, [1-6](#)
 Inner Top Cover, [1-4](#)
 Key Pad, [1-18](#)
 LCD, [1-14](#)
 Outer Cover, [1-2](#)
 Power Switch, [1-20](#)
 Rear Panel (N5181A), [1-40](#)
 Rear Panel (N5182A), [1-42](#)
 Tested USB Board, [1-10](#)

B

battery, replacement, [1-34](#)
before you replace an assembly, [1-1](#)

C

cables, [2-10](#)
certification, [4-2](#)
CPU, replacement, [1-38](#)

D

documentation, [ii-ix](#)

E

electrostatic discharge supplies, [2-19](#)
emi display with gasket, replacement, [1-16](#)

F

fan, replacement, [1-44](#)
frequency accuracy check, [3-3](#)
frequency range and accuracy check, [3-3](#)
front panel, replacement, [1-8](#)

G

guides, content of, [ii-ix](#)

H

hardware, [2-13](#)
hardware list, [2-2](#)

I

inner bottom cover, replacement, [1-6](#)
inner top cover, replacement, [1-4](#)
installation guide content, [ii-ix](#)

K

key pad, replacement, [1-18](#)

kits

 service, [2-6](#)

L

lcd, replacement, [1-14](#)
lists
 assemblies and hardware options, [2-2](#)
 cables, [2-10](#)
 hardware, [2-13](#)
 replaceable assemblies, [1-1](#)
lithium battery
 disposal, [4-2](#)
 replacement, [1-34](#)

M

manuals, content of, [ii-ix](#)
memory chip, replacement, [1-36](#)

O

operation verification, [3-1](#)
options, descriptions, [2-2](#)
outer cover, replacement, [1-2](#)
output power, checking, [3-6](#)

P

power
 checking, [3-6](#)
power supply, replacement, [1-22](#)
power switch, replacement, [1-20](#)
programming guide content, [ii-ix](#)

R

rear panel (N5181A), replacement, [1-40](#)
rear panel (N5182A), replacement, [1-42](#)
references, content of, [ii-ix](#)
replaceable parts
 assemblies, [1-1](#)
 cables, [2-10](#)
 hardware, [2-13](#)
 ordering information, [2-1](#)
rf assembly, replacement, [1-26](#), [1-30](#)

S

safety, general considerations, [4-1](#)
SCPI
 reference content, [ii-ix](#)
self test, [3-1](#)
service
 guide content, [ii-ix](#)
service kits, [2-6](#)

T

tested USB board, replacement, [1-10](#)
troubleshooting, [1-1](#)
troubleshooting output power, [3-6](#)

U

user
 documentation content, [ii-ix](#)

V

vector modulation assembly, replacement, [1-24](#)
verification, operation, [3-1](#)